



FIERY ZX
INSTALLATION AND SERVICE GUIDE

for Ricoh digital copiers

A guide for service technicians

ELECTRONICS FOR IMAGING, INC.

Part Number: 10016326

Copyright © 1998 Electronics for Imaging, Inc. All rights reserved.

This publication is protected by copyright, and all rights are reserved. No part of it may be reproduced or transmitted in any form or by any means for any purpose without express prior written consent from Electronics for Imaging, Inc., except as expressly permitted herein. Information in this document is subject to change without notice and does not represent a commitment on the part of Electronics for Imaging, Inc.

The software described in this publication is furnished under license and may only be used or copied in accordance with the terms of such license.

Patents: 5,666,436; 5,553,200; 5,543,940; 5,537,516; 5,517,334; 5,506,946; 5,424,754; 5,343,311; 5,212,546; 4,941,038; 4,837,722; 4,500,919

Trademarks

EFI, the EFI logo, Fiery, the Fiery logo, EFICOLOR, and Rip-While-Print are trademarks registered in the U.S. Patent and Trademark Office. Fiery ZX, Fiery LX, Fiery Driven, the Fiery Driven logo, Command WorkStation, AutoCal, Starr Compression, Memory Multiplier, ColorWise, NetWise, and VisualCal are trademarks of Electronics for Imaging, Inc.

Adobe, the Adobe logo, Adobe Illustrator, PostScript, Adobe Photoshop, Adobe Separator, and Adobe PageMaker are trademarks of Adobe Systems Incorporated, registered in certain jurisdictions. EPS (Encapsulated PostScript) is a trademark of Altsys Corporation. Apple, the Apple logo, AppleShare, AppleTalk, EtherTalk, LaserWriter, and Macintosh are registered trademarks, and MultiFinder is a trademark of Apple Computer, Inc. Microsoft, MS, MS-DOS, and Windows are registered trademarks of Microsoft in the US and other countries. QuarkXPress is a registered trademark of Quark, Inc. Times, Helvetica, and Palatino are trademarks of Linotype AG and/or its subsidiaries. ITC Avant Garde, ITC Bookman, ITC Zapf Chancery, and ITC Zapf Dingbats are registered trademarks of International Typeface Corporation. Ethernet is a registered trademark of Xerox Corporation. Farallon, PhoneNET PC, and PhoneNET Talk are trademarks of Farallon Computing, Inc. COPS and COPSTalk are trademarks of CoOperative Printing Solutions, Inc. NetWare and Novell are registered trademarks and Internetwork Packet Exchange (IPX) is a trademark of Novell, Inc. SyQuest is a registered trademark, in the United States and certain other countries, of SyQuest Technology, Inc. UNIX is a registered trademark of UNIX System Laboratories, a wholly owned subsidiary of Novell, Inc. PANTONE is a registered trademark of Pantone, Inc.

All other terms and product names may be trademarks or registered trademarks of their respective owners, and are hereby acknowledged.

Legal Notices

APPLE COMPUTER, INC. ("APPLE") MAKES NO WARRANTIES, EXPRESS OR IMPLIED, INCLUDING WITHOUT LIMITATION THE IMPLIED WARRANTIES OF MERCHANTABILITY AND FITNESS FOR A PARTICULAR PURPOSE, REGARDING THE APPLE SOFTWARE. APPLE DOES NOT WARRANT, GUARANTEE, OR MAKE ANY REPRESENTATIONS REGARDING THE USE OR THE RESULTS OF THE USE OF THE APPLE SOFTWARE IN TERMS OF ITS CORRECTNESS, ACCURACY, RELIABILITY, CURRENTNESS, OR OTHERWISE. THE ENTIRE RISK AS TO THE RESULTS AND PERFORMANCE OF THE APPLE SOFTWARE IS ASSUMED BY YOU. THE EXCLUSION OF IMPLIED WARRANTIES IS NOT PERMITTED BY SOME STATES. THE ABOVE EXCLUSION MAY NOT APPLY TO YOU.

IN NO EVENT WILL APPLE, ITS DIRECTORS, OFFICERS, EMPLOYEES OR AGENTS BE LIABLE TO YOU FOR ANY CONSEQUENTIAL, INCIDENTAL OR INDIRECT DAMAGES (INCLUDING DAMAGES FOR LOSS OF BUSINESS PROFITS, BUSINESS INTERRUPTION, LOSS OF BUSINESS INFORMATION, AND THE LIKE) ARISING OUT OF THE USE OR INABILITY TO USE THE APPLE SOFTWARE EVEN IF APPLE HAS BEEN ADVISED OF THE POSSIBILITY OF SUCH DAMAGES. BECAUSE SOME STATES DO NOT ALLOW THE EXCLUSION OR LIMITATION OF LIABILITY FOR CONSEQUENTIAL OR INCIDENTAL DAMAGES, THE ABOVE LIMITATIONS MAY NOT APPLY TO YOU. Apple's liability to you for actual damages from any cause whatsoever, and regardless of the form of the action (whether in contract, tort [including negligence], product liability or otherwise), will be limited to \$50.

Restricted Rights Legends

For defense agencies: Restricted Rights Legend. Use, reproduction, or disclosure is subject to restrictions set forth in subparagraph (c)(1)(ii) of the Rights in Technical Data and Computer Software clause at 252.227.7013.

For civilian agencies: Restricted Rights Legend. Use, reproduction, or disclosure is subject to restrictions set forth in subparagraph (a) through (d) of the commercial Computer Software Restricted Rights clause at 52.227-19 and the limitations set forth in Electronics for Imaging, Inc.'s standard commercial agreement for this software. Unpublished rights reserved under the copyright laws of the United States.

Printed in the United States of America on recycled paper.

FCC Information

WARNING: FCC Regulations state that any unauthorized changes or modifications to this equipment not expressly approved by the manufacturer could void the user's authority to operate this equipment.

NOTE: This equipment has been tested and found to comply with the limits for a Class A digital device, pursuant to Part 15 of the FCC Rules. These limits are designed to provide reasonable protection against harmful interference when the equipment is operated in a commercial environment. This equipment generates, and uses, and can radiate radio frequency energy and, if not installed and used in accordance with the instruction manual, may cause harmful interference to radio communications. Operation of this equipment in a residential area is likely to cause interference in which case the user will be required to correct the interference at his own expense.

Industry Canada Class A Notice

This digital apparatus does not exceed the Class A limits for radio noise emissions from digital apparatus as set out in the interference-causing equipment standard entitled, "Digital Apparatus" ICES-003 from Industry Canada.

Avis de Conformation Classe A d l'Industrie Canada

Le présent appareil numérique n'émet pas de bruits radioélectriques dépassant les limites applicables aux appareils numériques de la Classe A prescrites dans la norme sur le matériel brouilleur, "Appareils Numériques" NMB-003 édictée par l'Industrie Canada.

Certificate by Manufacturer/Importer

This is to certify that the FC07 is shielded against radio interference in accordance with the provisions of VFG 243/1991. The German Postal Services have been advised that this device is being put on the market and that they have been given the right to inspect the series for compliance with the regulations.
Electronics for Imaging, Inc.

Bescheinigung des Herstellers/Importeurs

Hermit wird bescheinigt, dass der FC07 im Uebereinstimmung mit den Bestimmungen der VFG 243/1991 Funk-Entstort ist. Der Deutschen Bundespost wurde das Inverkehrbringen dieses Gerates angezeigt und die Berechtigung zur Ueberpruefung der Serie auf Einhaltung der Bestimmungen eingeräumt.
Electronics for Imaging, Inc.

RFI Compliance Notice

This equipment has been tested concerning compliance with the relevant RFI protection requirements both individually and on system level (to simulate normal operation conditions). However, it is possible that these RFI Requirements are not met under certain unfavorable conditions in other installations. It is the user who is responsible for compliance of his particular installation.

Dieses Gerat wurde einzeln sowohl als auch in einer Anlage, die einen normalen Anwendungsfall nachbildet, auf die Einhaltung der Funk-entstortbestimmungen geprueft. Es ist jedoch moeglich, dass die Funk-entstortbestimmungen unter unguenstigen Umstaenden bei anderen Geratekombinationen nicht eingehalten werden. Fuer die Einhaltung der Funk-entstortbestimmungen seigner gesamten Anlage, in der dieses Gerat betrieben wird, ist der Betreiber verantwortlich.

Compliance with applicable regulations depends on the use of shielded cables. It is the user who is responsible for procuring the appropriate cables.

Einhaltung mit betreffenden Bestimmungen kommt darauf an, dass geschirmte Ausfuehrungen gebraucht werden. Fuer die beschaffung richtiger Ausfuehrungen ist der Betreiber verantwortlich.

Software License Agreement

Before using the Software, please carefully read the following terms and conditions. BY USING THIS SOFTWARE, YOU SIGNIFY THAT YOU HAVE ACCEPTED THE TERMS OF THIS AGREEMENT. If you cannot or do not accept these terms, you may return the entire package within ten (10) days to the Distributor or Dealer from which you obtained them for a full refund.

Electronics for Imaging, Inc. grants to you a non-exclusive, non-transferable license to use the software and accompanying documentation ("Software") included with the Fiery ZX you have purchased, including without limitation the PostScript® software provided by Adobe Systems Incorporated.

You may:

- a. use the Software solely for your own customary business purposes and solely with Fiery ZX;
- b. use the digitally-encoded machine-readable outline and bitmap programs ("Font Programs") provided with Fiery ZX in a special encrypted format ("Coded Font Programs") to reproduce and display designs, styles, weights, and versions of letters, numerals, characters and symbols ("Typefaces") solely for your own customary business purposes on the display window of the Fiery ZX or monitor used with Fiery ZX;
- c. use the trademarks used by Electronics for Imaging to identify the Coded Font Programs and Typefaces reproduced therefrom ("Trademarks"); and
- d. assign your rights under this Agreement to a transferee of all of your right, title and interest in and to Fiery ZX provided the transferee agrees to be bound by all of the terms and conditions of this Agreement.

You may not:

- a. make use of the Software, directly or indirectly, to print bitmap images with print resolutions of 600720 dots per inch or greater, or to generate fonts or typefaces for use other than with Fiery ZX;
- b. make or have made, or permit to be made, any copies of the Software, Coded Font Programs, accompanying documentation or portions thereof, except as necessary for use with the Fiery ZX unit purchased by you; provided, however, that under no circumstances may you make or have made, or permit to be made, any copies of that certain portion of the Software which has been included on the Fiery ZX hard disk drive. You may not copy the documentation;
- c. attempt to alter, disassemble, decrypt or reverse engineer the Software, Coded Font Programs or accompanying documentation.
- d. rent or lease the Software.

Proprietary Rights

You acknowledge that the Software, Coded Font Programs, Typefaces, Trademarks and accompanying documentation are proprietary to Electronics for Imaging and its suppliers and that title and other intellectual property rights therein remain with Electronics for Imaging and its suppliers. Except as stated above, this Agreement does not grant you any right to patents, copyrights, trade secrets, trademarks (whether registered or unregistered), or any other rights, franchises or licenses in respect of the Software, Coded Font Programs, Typefaces, Trademarks or accompanying documentation. You may not adapt or use any trademark or trade name which is likely to be similar to or confusing with that of Electronics for Imaging or any of its suppliers or take any other action which impairs or reduces the trademark rights of Electronics for Imaging or its suppliers. The trademarks may only be used to identify printed output produced by the Coded Font Programs. At the reasonable request of Electronics for Imaging, you must supply samples of any Typeface identified with a trademark.

Confidentiality

You agree to hold the Software and Coded Font Programs in confidence, disclosing the Software and Coded Font Programs only to authorized users having a need to use the Software and Coded Font Programs as permitted by this Agreement and to take all reasonable precautions to prevent disclosure to other parties.

Remedies

Unauthorized use, copying or disclosure of the Software, Coded Font Programs, Typefaces, Trademarks or accompanying documentation will result in automatic termination of this license and will make available to Electronics for Imaging other legal remedies.

Limited Warranty And Disclaimer

Electronics for Imaging warrants that, for a period of ninety (90) days from the date of delivery to you, the Software under normal use will perform without significant errors that make it unusable. Electronics for Imaging's entire liability and your exclusive remedy under this warranty (which is subject to you returning Fiery ZX to Electronics for Imaging or an authorized dealer) will be, at Electronics for Imaging's option, to use reasonable commercial efforts to attempt to correct or work around errors, to replace the Software with functionally equivalent software, or to refund the purchase price and terminate this Agreement. Some states do not allow limitations on duration of implied warranty, so the above limitation may not apply to you.

Except for the above express limited warranty, Electronics for Imaging makes and you receive no warranties or conditions on the Products, express, implied, or statutory, and Electronics for Imaging specifically disclaims any implied warranty or condition of merchantability or fitness for a particular purpose.

For warranty service, please contact your authorized service/support center.

EXCEPT FOR THE ABOVE EXPRESS LIMITED WARRANTY, ELECTRONICS FOR IMAGING MAKES AND YOU RECEIVE NO WARRANTIES OR CONDITIONS ON THE SOFTWARE OR CODED FONT PROGRAMS, EXPRESS, IMPLIED, STATUTORY, OR IN ANY OTHER PROVISION OF THIS AGREEMENT OR COMMUNICATION WITH YOU, AND ELECTRONICS FOR IMAGING SPECIFICALLY DISCLAIMS ANY IMPLIED WARRANTY OR CONDITION OF MERCHANTABILITY OR FITNESS FOR A PARTICULAR PURPOSE. Electronics for Imaging does not warrant that the operation of the software will be uninterrupted or error free or that the Software will meet your specific requirements.

Limitation Of Liability

IN NO EVENT WILL ELECTRONICS FOR IMAGING OR ITS SUPPLIERS BE LIABLE FOR ANY DAMAGES, INCLUDING LOSS OF DATA, LOST PROFITS, COST OF COVER OR OTHER SPECIAL, INCIDENTAL, CONSEQUENTIAL OR INDIRECT DAMAGES ARISING FROM THE USE OF THE SOFTWARE, CODED FONT PROGRAMS OR ACCOMPANYING DOCUMENTATION, HOWEVER CAUSED AND ON ANY THEORY OF LIABILITY. THIS LIMITATION WILL APPLY EVEN IF ELECTRONICS FOR IMAGING OR ANY AUTHORIZED DEALER HAS BEEN ADVISED OF THE POSSIBILITY OF SUCH DAMAGE. YOU ACKNOWLEDGE THAT THE PRICE OF THE UNIT REFLECTS THIS ALLOCATION OF RISK. BECAUSE SOME STATES/JURISDICTIONS DO NOT ALLOW THE EXCLUSION OR LIMITATION OF LIABILITY FOR CONSEQUENTIAL OR INCIDENTAL DAMAGES, THE ABOVE LIMITATION MAY NOT APPLY TO YOU.

Export Controls

You agree that you will not export or re-export the Software or Coded Font Programs in any form without the appropriate United States and foreign government licenses. Your failure to comply with this provision is a material breach of this Agreement.

Government Use

Use, duplication or disclosure of the Software by the United States Government is subject to restrictions as set forth in subdivision (c) (1) (ii) of the Rights in Technical Data and Computer Software clause at DFARS 252.227-7013 or in subparagraphs (c) (1) and (2) of the Commercial Computer Software—Restricted Right Clause at 48 CFR 52.227-19, as applicable.

Third Party Beneficiary

You are hereby notified that Adobe Systems Incorporated, a California corporation located at 345 Park Avenue, San Jose, CA 95110-2704 ("Adobe") is a third-party beneficiary to this Agreement to the extent that this Agreement contains provisions which relate to your use of the Fonts, the Coded Font Programs, the Typefaces and the Trademarks licensed hereby. Such provisions are made expressly for the benefit of Adobe and are enforceable by Adobe in addition to Electronics for Imaging.

General

This Agreement will be governed by the laws of the State of California.

This Agreement is the entire agreement held between us and supersedes any other communications or advertising with respect to the Software, Coded Font Programs and accompanying documentation.

If any provision of this Agreement is held invalid, the remainder of this Agreement shall continue in full force and effect.

If you have any questions concerning this Agreement, please write to Electronics for Imaging, Inc., Attn: Licensing Dept. or see Electronics for Imaging's web site at www.efi.com.

Electronics for Imaging, Inc.
2855 Campus Drive
San Mateo, CA 94403

Contents

Preface

About this guide	xi
About the illustrations in this guide	xi
Terminology and conventions	xii
Precautions	xiii
Tools you will need	xv

Chapter 1: Introduction

Features	1-1
How the Fiery ZX operates	1-2
Fiery ZX print options	1-3
User software	1-4
Fiery WebTools	1-5

Chapter 2: Preparing for Fiery ZX Installation

Installation sequence	2-1
Checking the customer site	2-3
Setting customer expectations	2-4
Unpacking the Fiery ZX	2-5
Fiery ZX panels	2-7

Chapter 3: Connecting the Fiery ZX

Preliminary checkout	3-1
Connecting to the copier	3-3
Verifying the connection	3-5
Printing the Fiery ZX Test Page	3-5
Checking scanning and printing	3-6
Installing additional options	3-7
Connecting to the network	3-7
Ethernet network connections	3-8
Connecting a PC-compatible to the Fiery ZX	3-11
Using the Control Panel	3-13
Activity light	3-14
Buttons	3-14
Control Panel screens and icons	3-15
Shutting down and restarting the Fiery ZX	3-20

Contents

Chapter 4: Service Procedures

Overview	4-1
System software service	4-1
Accessing Fiery ZX internal components	4-3
Accessing front panel components	4-6
Checking Fiery ZX internal connections	4-8
Restoring Fiery ZX functionality after service	4-11
Removing and replacing circuit boards	4-13
MXV board	4-13
Video interface board	4-15
STARR daughter card	4-17
User interface board	4-20
Motherboard	4-23
Removing the Fiery ZX motherboard	4-24
Replacing the motherboard	4-27
Replacing parts on the motherboard	4-28
Motherboard jumpers	4-32
HDD backplane board	4-34
Fans	4-36
Back panel fan	4-36
CPU fan	4-37
Power supply	4-37
Checking voltages	4-38
Removing and replacing the power supply	4-39
Hard disk drive	4-40
CD-ROM drive	4-45
Front panel components	4-47
Jewels	4-48
Buttons	4-48
Fiery ZX system software	4-49

Contents

Chapter 5: Troubleshooting

The troubleshooting process	5-1
Where problems occur	5-2
Before you go to the customer site	5-3
Preliminary on-site checkout	5-4
Checking the interface cables	5-5
Checking the internal components	5-6
Checking the Fiery ZX as a stand-alone unit	5-8
Isolating the Fiery ZX	5-8
Errors and beep codes during startup diagnostics	5-9
General Fiery ZX system error conditions	5-13
Viewing the diagnostic Info screen	5-15
Video interface board diagnostics	5-16
Checking the entire Fiery ZX system	5-18
Checking the copier interface	5-18
Checking network connections	5-21
Printing to the Fiery ZX	5-22

Appendix A: Specifications

Hardware features	A-1
Networking and connectivity	A-1
User software	A-1
Safety and emissions compliance	A-1

Index

About this guide

Preface

The *Installation and Service Guide* is intended for certified Fiery ZX™ and copier service technicians installing or servicing a Fiery ZX Color Server. If you have not received installation and service certification, you should not attempt to install or service a Fiery ZX Color Server. Electronics for Imaging, Inc. does not warrant the performance if installed or serviced by non-certified personnel.

About this guide

This guide covers the following topics:

- “Preface”
General information about this guide and about installing the Fiery ZX
- Chapter 1, “Introduction”
General information about the Fiery ZX
- Chapter 2, “Preparing for Fiery ZX Installation”
Unpacking and the steps you need to take before you install the unit
- Chapter 3, “Connecting the Fiery ZX”
How to connect the Fiery ZX to the copier and the network and verify that the system is working correctly; overview of the Control Panel
- Chapter 4, “Service Procedures”
Removal and replacement procedures for Fiery ZX components
- Chapter 5, “Troubleshooting”
Common problems and ways of correcting them; startup error codes
- The *Configuration Guide* is also provided under separate cover at the back of this manual. It provides information on the different network environments and how to configure Fiery ZX Setup options.

NOTE: Fiery ZX customers should not use the technical service documentation. Please don't leave your copy of the *Installation and Service Guide* behind after you make a service call.

About the illustrations in this guide

The illustrations in this guide reflect the current shipping version of the Fiery ZX at the time of publication. Components shown in these illustrations are subject to change. To receive information about any Fiery ZX components that do not match the illustrations in this guide, contact your authorized service/support center.

Terminology and conventions

The term “Fiery ZX” is used throughout this manual to refer to both Fiery ZX3200 and Fiery ZX3300. Fiery ZX3200 models have a standard memory configuration of 160MB; Fiery ZX3300 models have a standard memory configuration of 256MB.

The term “network administrator” refers to the person responsible for maintaining the network at the customer site.

The term “Control Panel” refers to the area on the front of the Fiery ZX including the green/red activity light, the display window (LCD—liquid crystal display), and the buttons to the right of and below the display window.

The term “system software” refers to the software installed on the Fiery ZX hard disk drive.

The term “PC-compatible” refers to any device that may be connected to the Fiery ZX for parallel printing.

The term “100BaseT” is used throughout this manual to refer to 100BaseTX.

References to other Fiery ZX manuals, such as the *Configuration Guide*, are displayed in italics.

NOTE: The note format highlights important messages and additional information.



The caution icon indicates a need for special care and safety when handling the equipment.

Fiery ZX Control Panel screen messages and commands referred to in the text of this manual appear in the Officina Sans typeface.

Precautions

Precautions

Always observe the following general precautions when installing and servicing the Fiery ZX:

- 1. Report any shipping damage.**

If there is any evidence of shipping or handling damage to the Fiery ZX packing boxes or their contents, save the damaged boxes and parts, call the shipper immediately to file a claim, and notify your authorized service/support center.
- 2. Never alter an existing network without permission.**

The Fiery ZX will probably be connected to an existing Local Area Network (LAN) based on Ethernet hardware. The network is the link between the customer's computer, existing laser printers, and other prepress equipment. Never disturb the LAN by breaking or making a network connection, altering termination, installing or removing networking hardware or software, or shutting down networked devices without the knowledge and express permission of the system or network administrator or the shop supervisor.
- 3. Never enter an IP address in Fiery ZX Network Setup.**

Only the network administrator should enter an IP address on a network device. Assigning the Fiery ZX an incorrect IP address may cause unpredictable errors on any or all devices connected to the network.
- 4. Always disconnect power before opening the Fiery ZX.**

Although Fiery ZX circuitry operates on 5V DC and 12V DC, 115V AC is present when the cover is removed. Before you service the Fiery ZX, shut it down completely and unplug the AC power cable from the back of the Fiery ZX.
- 5. Handle the Fiery ZX Control Panel display window with care.**

The Fiery ZX display window is made of glass. If the glass breaks and the liquid crystal inside leaks out, avoid contact with it. If you do come in contact with the liquid crystal, wash it off with soap and water immediately.
- 6. Avoid pressing the surface of the display window.**

Applying pressure to the display window will cause it to change color.
- 7. Use a soft cloth moistened with isopropyl or ethyl alcohol to clean the surface of the Fiery ZX display window.**

Other solvents, such as water, may damage the polarizer on the display window.

Preface

8. Use care when handling parts of the Fiery ZX as some edges on the unit may be sharp. For example, be careful when:

- Accessing the CD-ROM drive (keep the drive door closed when not in use)
- Plugging in cables at the back of the unit
- Using the power switch to power on/off the unit

9. Follow standard ESD (electrostatic discharge) precautions while working on the internal components of the Fiery ZX.

Static is always a concern when servicing electronic devices. It is highly unlikely that the area around the copier and the Fiery ZX is static-free. Carpeting, leather-soled shoes, synthetic clothing fibers, silks, and plastics may generate a static charge of more than 10,000 volts. Static discharge is capable of destroying the circuits etched in silicon microchips, or dramatically shortening their life span. By observing standard precautions, you may avoid extra service calls and save the cost of a new board.

When possible, work on a ground-connected antistatic mat. Wear an antistatic grounding strap, grounded at the same place as the antistatic mat. If that is not possible:

- Attach a grounding strap to your wrist. Attach the other end to a good ground.
 - When you unpack the Fiery ZX from the carton for the first time, touch a metal area of the copier to discharge the static on your body.
 - Before you remove the Fiery ZX side panel and before you handle internal components, touch a metal part of the Fiery ZX.
 - Leave new electronic components inside their antistatic bags until you are ready to install them. When you remove components from an antistatic bag, place them on a grounded antistatic surface, component-side up.
 - When you remove an electronic component, place it into an antistatic bag immediately. Do not walk across a carpet or vinyl floor while carrying an unprotected board.
10. Handle printed circuit boards by their edges only, but avoid touching the contacts on the edge of the board.
 11. Never set a cup of coffee—or any liquid—on or near the Fiery ZX or the copier.

Tools you will need

Tools you will need

To install or service the Fiery ZX, you should bring the following tools and parts:

- ESD wrist grounding strap and antistatic mat
- Wire cutters
- #0 and #1 Phillips head screwdrivers (non-magnetic)
- 3/16" hex nut driver
- Flashlight

You should also bring this guide and any technical notes for the Fiery ZX.

Chapter 1: Introduction

The Fiery ZX Color Server adds computer connectivity and highly efficient Adobe PostScript 3 color printing capacity to color copiers. It is optimized for high-speed network communications, processing, rasterization, and printing of continuous tone color and monochrome pages.

Features

The Fiery ZX, as an integral part of a color printing system, enables users of PC-compatibles, Mac OS computers, and UNIX workstations to:

- Send images over AppleTalk, TCP/IP, and Novell networks to print on Fiery ZX supported devices.
- Spool print jobs and select a printing priority for each job. Users can control spooled print jobs sent to the Fiery ZX with remote utility software running on networked PC-compatible and Mac OS computers.
- Print files, in color, grayscale, and black and white.
- Use the copier as a high-resolution color scanner with Fiery Scan software.
- Use 136 resident fonts (117 Adobe Type 1 PostScript, and 19 TrueType), plus two Adobe Multiple Master fonts used for font substitution when printing PDF files.

The Fiery Downloader or any third-party LaserWriter downloader, such as the Adobe Font Downloader, can be used to download additional fonts.

- Use built-in ColorWise™ color management and NetWise™ network features.

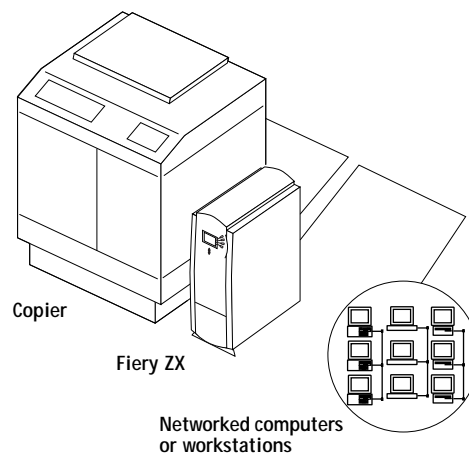

FIGURE 1-1 Fiery ZX printing system

The Fiery ZX is one of several imaging products engineered and manufactured by Electronics for Imaging, Inc.

1 Introduction

How the Fiery ZX operates

The Fiery ZX enables the customer to use a color copier as a printer and scanner. Users can print to the Fiery ZX from networked PC-compatibles running Microsoft Windows, from networked Mac OS computers, and from networked UNIX workstations running TCP/IP. In addition, the Fiery ZX parallel port can be used to print directly from a PC-compatible.

The Fiery ZX custom-designed boards and system software are responsible for efficient image processing and printing controls. The main functions of Fiery ZX components and software are described below.

The Fiery ZX uses specialized circuit boards, the motherboard and the video interface board, to process image data for printing and scanning images.

The motherboard includes an Alpha 21164 533MHz CPU chip which controls the image data transfer to and from the video interface board and runs the PostScript interpreter. The PostScript interpreter rasterizes the PostScript page description file and then compresses the image pattern into memory using compression technology.

The PostScript interpreter outputs compressed raster data through the image frame buffer memory to the Fiery ZX STARR daughter card installed on the video interface board. The STARR daughter card decompresses the image data and sends it to the copier through the video interface board and the copier interface cable. The raster data supplied to the laser in the copier charges the drum and renders the final image on paper at full copier engine speed.

High-speed DIMMs (dual in-line memory modules) on the motherboard hold the image data during printing. The Fiery ZX is configured with 160MB or 256MB of memory.

When Fiery Scan™ uses the copier as a scanner, the Fiery ZX acquires RGB (red, green, and blue) image data from the copier, stores it in memory, and transmits it to the computer that requested the scan.

1 Fiery ZX print options

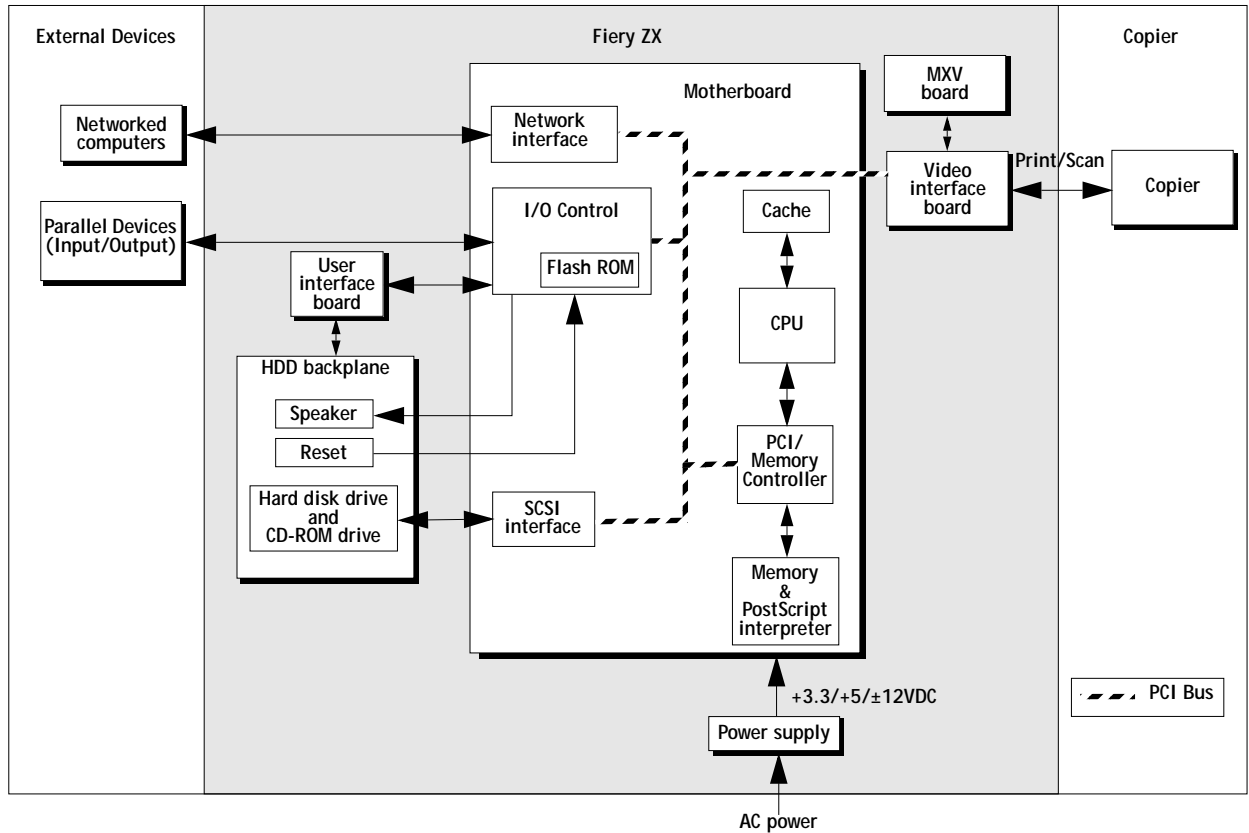

FIGURE 1-2 Fiery ZX functional diagram

Fiery ZX print options

The Fiery ZX's efficient capabilities allow users to use a variety of applications to create and print pages of text and/or images. The Fiery ZX operates over a network or through the parallel port.

Printing over a network allows Fiery ZX users to print documents directly from applications in which they were created. In addition, the Fiery ZX offers an efficient way to print files that have been saved in PostScript, EPS (Encapsulated PostScript), or PDF (Portable Document Format). These files can be downloaded directly to the Fiery ZX using the Fiery Downloader™, one of the remote utilities for use with the Fiery ZX.

In addition, customers can print documents directly from applications running on a PC-compatible connected to the Fiery ZX parallel port. PostScript files can also be printed to the parallel port from Windows, including the MS-DOS window.

User software

Fiery ZX user software is provided on the User Software CD and the Command WorkStation CD. Some of the software can also be installed from the Fiery WebTools Installer (see *Getting Started* for more information on WebTools). The network administrator or user at the customer site is responsible for installing software onto computers that will use the Fiery ZX over the network.

The following user software is included:

Adobe PS Printer Driver	Enables users to print to the Fiery ZX from PC-compatible and Mac OS computers; also supports special Fiery ZX print features and PostScript 3 features.
PostScript Printer Description file (PPD)	File for use with the PS printer driver that allows the Fiery ZX to appear in popular applications' Print and Page Setup dialog boxes. The PPD provides information about the Fiery ZX and the particular copier model to the application and printer driver being used.
PostScript Screen Fonts	Screen fonts for the 136 PostScript printer fonts installed on the Fiery ZX (117 Adobe Type 1 and 19 TrueType). See the <i>Printing Guide</i> for a complete list.
Fiery Downloader™	Enables users to print PostScript files, EPS (Encapsulated PostScript) files, and PDF (Portable Document Format) files directly to the Fiery ZX without opening the application in which they were created. The Fiery Downloader also enables users to manage the printer fonts installed on the Fiery ZX. Fiery Downloader is also installed with the Command WorkStation software.
Fiery Print Calibrator™	Enables users to calibrate the Fiery ZX remotely from their computer. Proper calibration keeps color consistent across time and from job to job. Fiery Print Calibrator is also installed with the Command WorkStation software.

1 User software

Fiery Spooler™	Enables users to view the order and priority of print jobs, customize printer settings for jobs, delete jobs, and move jobs between queues. Users can also view job accounting information.
Fiery Scan™ Plug-in	A TWAIN plug-in module for Photoshop that enables users to scan images from the copier directly into Photoshop.
For Fiery ZX3300, Command WorkStation (on Command WorkStation CD)	Enables users to run the Command WorkStation application from a remote workstation. For more information on using the Command WorkStation, see the <i>Job Management Guide</i> .
Color management files	ColorSync and ICM color management files that enable users to maintain consistent color from the original artwork to the colors displayed on the monitor to the printed output.
Color reference files	Reference pages that users can print to view the range of colors available on the Fiery ZX.

Fiery WebTools

The Fiery ZX can support Internet or intranet access with Fiery WebTools, which include Status, WebSpooler, Installer, and WebLink. For more information on WebTools, see the *Configuration Guide* and *Getting Started*.

2

Installation sequence

Chapter 2: Preparing for Fiery ZX Installation

This chapter includes the following information:

- Summary of the installation sequence
- Checking the customer site
- Unpacking the Fiery ZX
- Fiery ZX front and back overview

Installation sequence

Familiarize yourself with Chapters 2 and 3 of this guide before you attempt an installation. The installation sequence described in this chapter is designed to make your job as easy as possible. Installation problems are easier to avoid and diagnose if you proceed from the component to the system level and verify functionality at each stage. Figure 2-1 on page 2-2 outlines the recommended installation procedure for connecting the Fiery ZX to the copier.

Because the Fiery ZX is a node on the customer's computer network, make sure that you coordinate your scheduled installation with the network administrator at the customer site. Refer the network administrator to the *Configuration Guide* for network setup information.

2 Preparing for Fiery ZX Installation

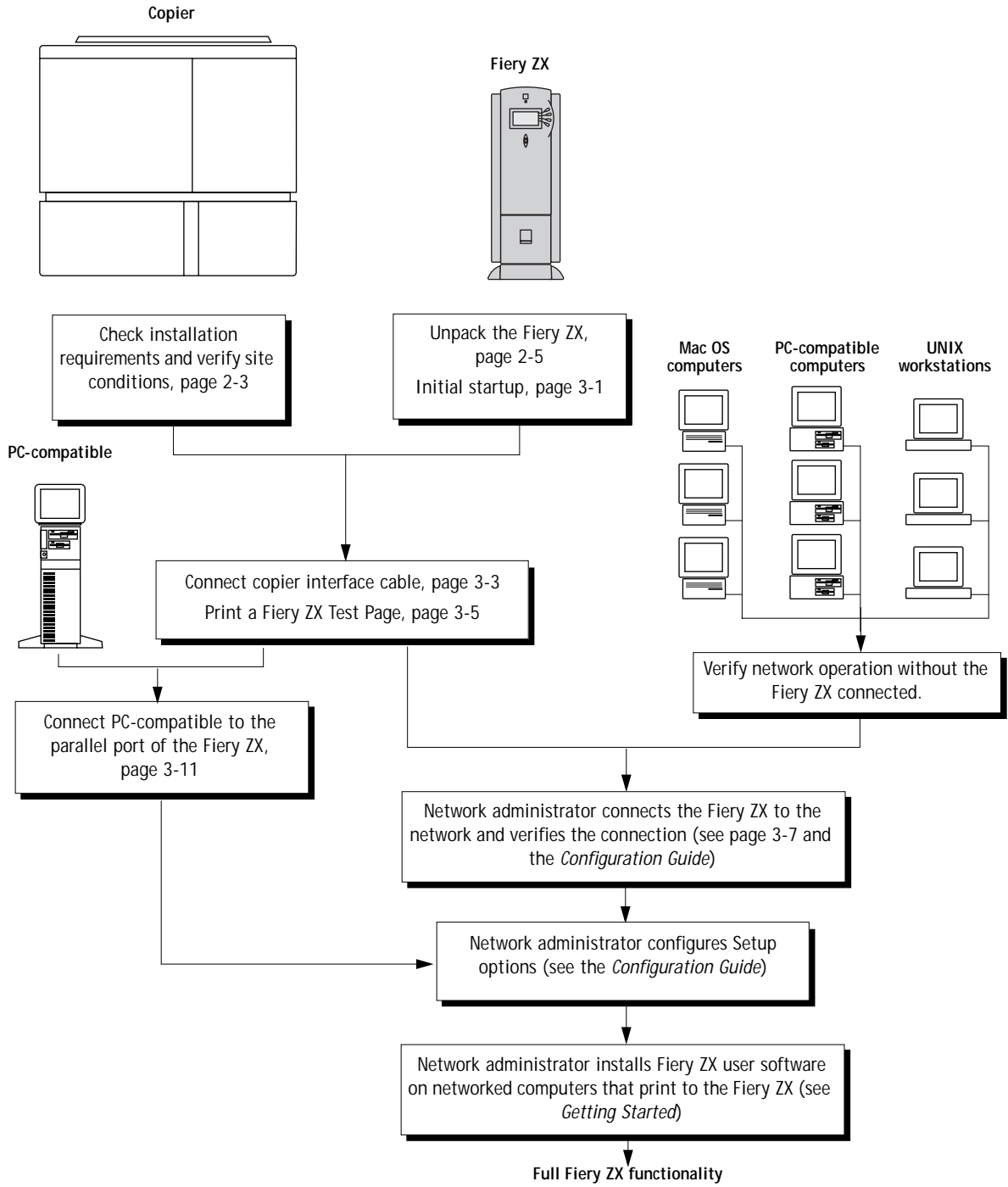

FIGURE 2-1 Recommended installation steps and references

2

Checking the customer site

Checking the customer site

Before you install the Fiery ZX, check site conditions and inform the customer of any installation requirements.

Copier model

- What copier model is installed?
- Is there space near the copier for the Fiery ZX?
Make sure that there is space for the Fiery ZX. You may need to move the copier out from the wall for easier access to the connectors.
- Does the copier require service or adjustments?
Copy the copier color test page before you install the Fiery ZX.
If the copied image indicates that the copier needs adjustment, inform the customer. After getting approval, complete the copier service needed.

Power

- Is there a dedicated grounded electrical outlet near the copier for the Fiery ZX?
Locate the grounded electrical outlet that will supply power to the Fiery ZX. You should not run the Fiery ZX and the copier on the same circuit. Use a surge suppressor for the Fiery ZX.
 - *Do not* use a 3-prong adapter in a 2-hole ungrounded outlet.
 - *Do not* use an extension cord.
 - *Do not* plug the Fiery ZX into a circuit with heating or refrigeration equipment (including water coolers).
 - *Do not* plug the Fiery ZX into a switchable wall outlet. This can result in the Fiery ZX being turned off accidentally.

Network

- What is the network cable and connection type?
 - Thinnet (10Base2)—Is an Ethernet transceiver available?
 - Thicknet (10Base5)
 - Unshielded twisted pair (10BaseT/100BaseT)
 - Did the customer order the Token Ring network option?

2

Preparing for Fiery ZX Installation

- Is the network connection ready and tested for Fiery ZX installation?

To verify that the network is functioning before you attach the Fiery ZX:

- Ask the network administrator to print a document on a shared printer over the network.
- Ask the network administrator to verify the computer and network requirements as specified in *Getting Started*.

Parallel port

- Is there room for both the Fiery ZX and the PC-compatible that will be connected to the Fiery ZX?

System contact person

- Will the person responsible for the computers and the network be available at the time set for installation? Get a name as a contact.

Setting customer expectations

If the site is ready, installation takes about one hour. The customer should be informed of the following:

- The network may be unavailable for up to one hour.
- The equipment may be unavailable for up to one hour.
- The network administrator needs to be available during the installation for network connectivity.

Equipment downtime and impact on the network can be minimized if the network administrator installs a network connector for the Fiery ZX and confirms network functionality with the connector in place before the date scheduled for the Fiery ZX installation.

- The network administrator should have a networked computer available during the installation. The appropriate software should already be installed. Documentation for the networked computer and the network operating software should be available.
- The network administrator should install the user software shipped with the Fiery ZX (user documentation is also included) onto networked PC-compatible and Mac OS computers that will print to the Fiery ZX.

NOTE: This guide covers Fiery ZX hardware installation and service. It provides general information on connecting the Fiery ZX to the customer's network. Network setup and configuration information goes beyond the scope of this guide. For network setup and configuration information, the network administrator should use the *Configuration Guide*.

2 Unpacking the Fiery ZX

Unpacking the Fiery ZX

The Fiery ZX is assembled and shipped from the factory in a box that includes all necessary cables and documentation, as shown in Figure 2-2 on page 2-6.

TO UNPACK THE FIERY ZX

Save the original boxes and packing materials. If you need to transport the Fiery ZX at a later date, the original box and packing material will ensure safe shipment.

1. Open the Fiery ZX Color Server box and remove the packing material.
2. Remove the contents from the top container. Inspect the contents for visible damage. The top container should include the following items:
 - Bags containing the copier interface cable (16' long with 100-pin D connectors), parallel cable, and two AC power cables (US and Europe).
 - AUI to BNC Ethernet Transceiver
 - Media package (includes a package of user documentation, and the User Software CD)
Fiery ZX3300 systems also include the Command WorkStation CD.

NOTE: A service kit containing the System Software CD is provided separately.

3. Give the media package to the customer or the network administrator.
Let the customer or network administrator know that in order to take full advantage of the Fiery ZX, the user software must be installed on computers that will print to the Fiery ZX.
4. Set aside the remaining components from the top container.
5. Remove the top container and any packing materials. Set aside the packing material in case you need to reship the unit.
6. Carefully lift the Fiery ZX out of the box.

If you notice shipping damage to any Fiery ZX component, be sure to save the shipping container in case the carrier needs to see it. Call the carrier immediately to report the damage and file a claim, then call your authorized service/support center. Be ready to furnish the serial number, printed on the back of the Fiery ZX.

2 Preparing for Fiery ZX Installation

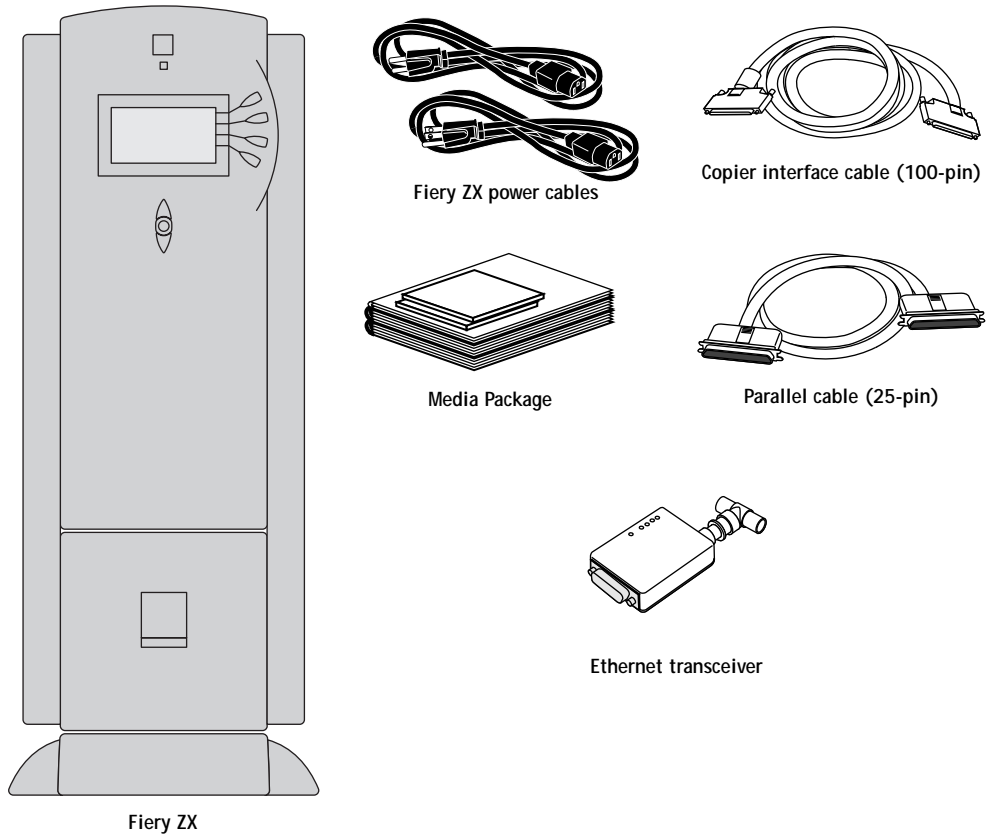

FIGURE 2-2 Contents of Fiery ZX shipping box

2 Fiery ZX panels

Fiery ZX panels

Once you have unpacked the Fiery ZX, you can familiarize yourself with the front and back of the Fiery ZX before you install it.

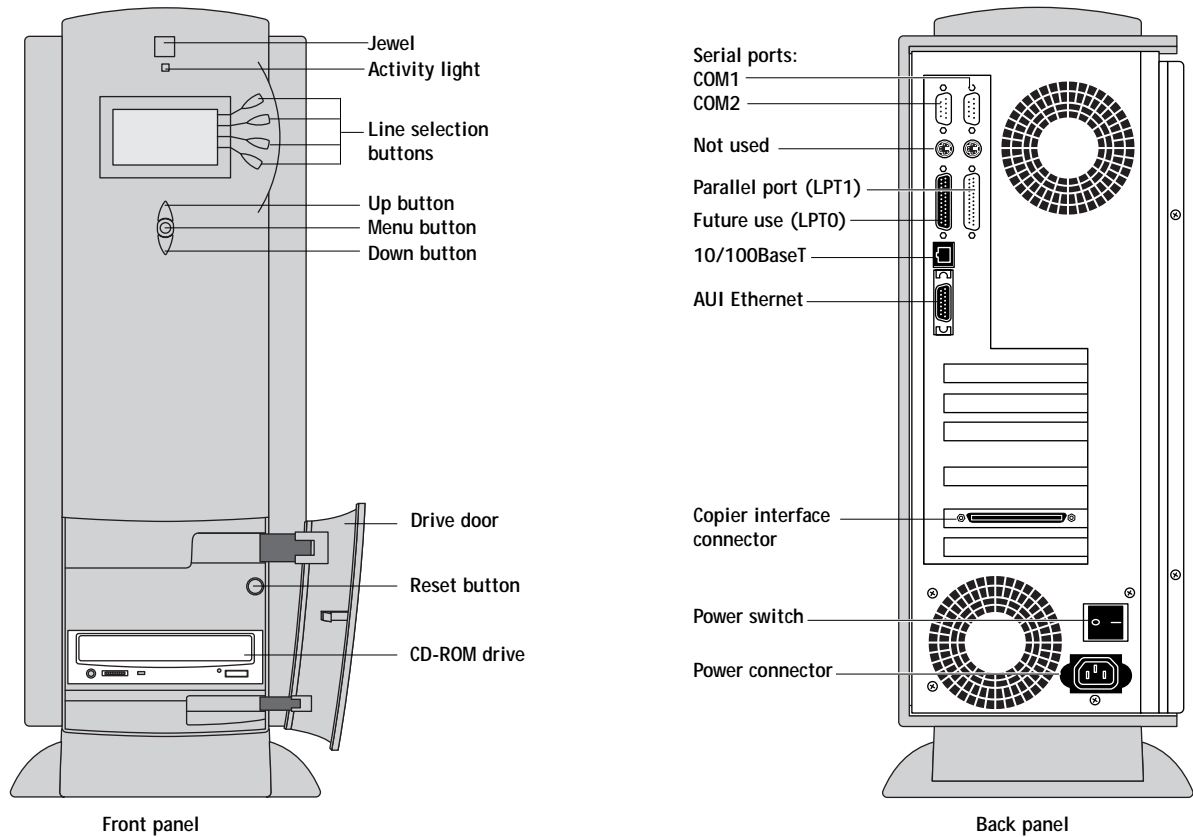

FIGURE 2-3 Front and back of the Fiery ZX

3 Preliminary checkout

Chapter 3: Connecting the Fiery ZX

When you have just unpacked or serviced a Fiery ZX, power it up before you connect it to the copier and the network. Diagnostics are run automatically during startup; the Fiery ZX is checked for internal problems.

Preliminary checkout

The following procedure describes how to connect power to the Fiery ZX.

TO CONNECT POWER AND START THE FIERY ZX

1. Connect the recessed end of the Fiery ZX power cable to the power connector at the back of the Fiery ZX (see Figure 3-1).
2. Make sure the Fiery ZX power switch is in the off position (press 0), and then connect the other end of the Fiery ZX power cable to a wall outlet.

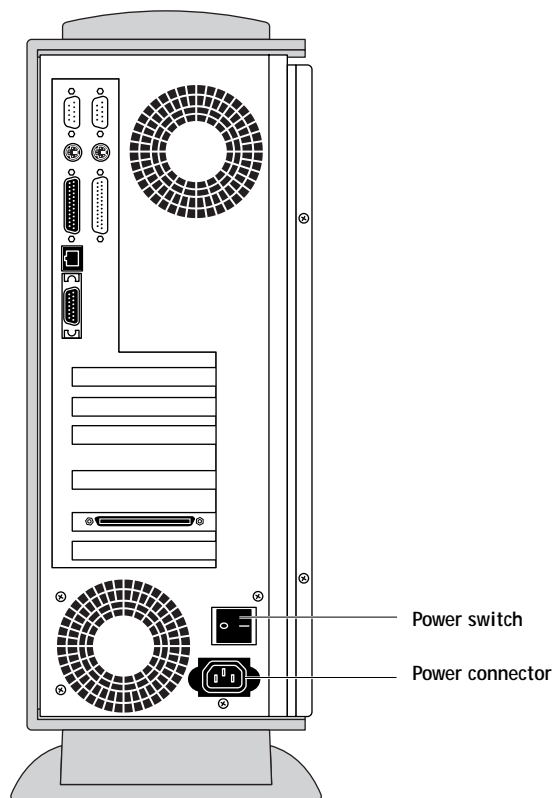

FIGURE 3-1 Fiery ZX power

3

Connecting the Fiery ZX

3. Power on the Fiery ZX using the switch at the back of the Fiery ZX. The power supply automatically senses the correct voltage.
4. To confirm that the Fiery ZX is operating properly allow Fiery ZX startup to proceed without interruption while you watch the Control Panel. Do not press any buttons on the Control Panel.

The Control Panel displays the Fiery ZX startup diagnostics. During the startup diagnostics the activity light on the Control Panel flashes green and then red to verify functionality.

If an error occurs during startup, the red activity light remains on at the end of the tests (see “Errors and beep codes during startup diagnostics” on page 5-9).

5. If the Select Language screen is displayed, select the language for the Control Panel.

The language screen is displayed the first time you start the Fiery ZX after unpacking it and after installing system software.

To select a language different from the one initially highlighted on the Control Panel, use the up and down buttons to scroll through the list and select OK when the desired language is highlighted. After the Fiery ZX reboots, messages in the language you selected will appear on the Control Panel.

6. If the Setup screen is displayed, select Printer, Server, Network, and then Exit Setup.

To exit Setup, you must first enter Printer Setup, Server Setup, and Network Setup, and save changes. To skip through the Setup options, press the menu key to access the Save Changes screen and select Yes which configures each Setup with the default configuration. At this stage the default settings are adequate although they may not be optimal. After the Fiery ZX is connected to the network, the customer can reset options according to the network and user environment. For more information, see the *Configuration Guide*.

7. Allow the system to proceed to Idle to confirm that the Fiery ZX is operating correctly.

Once the Fiery ZX reaches the idle state, you are ready to connect it to the copier and the network. Setup options should be configured after making this connection.



3

Connecting to the copier

Connecting to the copier

After completing the preliminary checkout, connect the Fiery ZX to the copier. The Fiery ZX communicates with the copier through a cable from the video interface board to the copier interface port.

TO CONNECT THE FIERY ZX TO THE COPIER

1. Power off the Fiery ZX and the copier.

You may need to get permission from the network administrator or supervisor to power off the copier.

If the system has just finished processing, wait 5 seconds after the system reaches the idle state before using the power switch to shut down the unit.

2. Make sure the Fiery ZX is near the copier.
3. Locate the Fiery ZX copier interface cable and connect one end of the cable to the copier interface port on the copier.

Be sure to tighten the screws completely.

4. Connect the other end of the cable to the Fiery ZX copier interface connector in slot 5 (see Figure 3-2 on page 3-4).

Be sure to tighten the screws completely.

3 Connecting the Fiery ZX

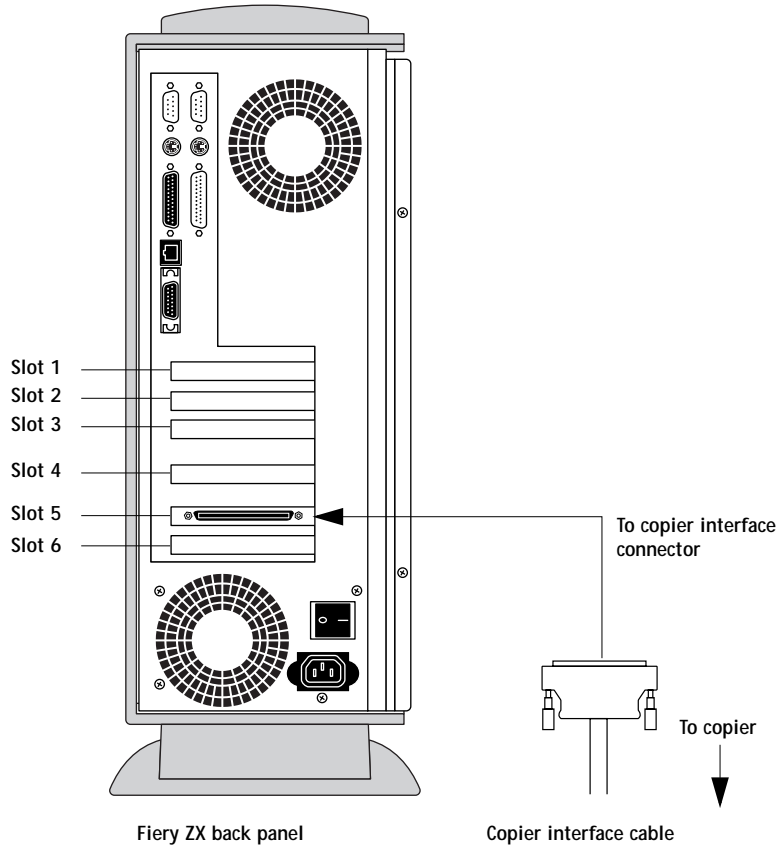

FIGURE 3-2 Copier interface cable connection

3

Verifying the connection

Verifying the connection

After you connect the Fiery ZX to the copier, print a Test Page and perform the Test Scan/Print function to verify that the connection between the Fiery ZX and the copier is good.

Printing the Fiery ZX Test Page

TO PRINT A TEST PAGE FROM THE CONTROL PANEL

1. Power on the copier and allow it to warm up.
2. Power on the Fiery ZX from the power switch on the back panel.
Messages appear on the Control Panel as the Fiery ZX runs through its startup diagnostics.
3. Before proceeding, make sure that the copier is not in use.
The Fiery ZX Info screen should read Idle.
4. At the Idle screen, press the menu button once (see "Using the Control Panel" on page 3-13).

The Functions menu is shown below:

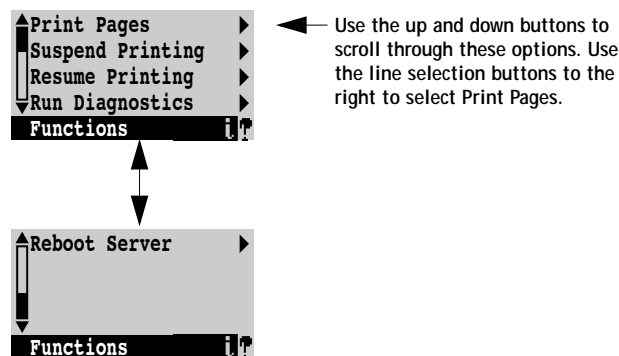

FIGURE 3-3 Functions menu

5. Press the line selection button to the right of Print Pages and then select Test Page.
The Fiery ZX sends the Test Page, a color PostScript file that is resident on the Fiery ZX hard disk drive, to the copier and displays the RIP and Print status screens so you can monitor the job.
6. Examine the quality of the Test Page from the copier.
The Test Page confirms that the Fiery ZX print engine is functional and that the connection between the Fiery ZX and the copier is good. The next step is to check the Fiery ZX Test Scan/Print function.

3

Connecting the Fiery ZX

Checking scanning and printing

The Test Scan/Print function scans whatever is placed on the copier glass and prints it to the copier. This test can be used to check the scanning capabilities of the Fiery ZX. You can compare the original with the output to make sure the connection between the Fiery ZX and the copier is working properly.

TO RUN TEST SCAN/PRINT

1. Place the document that you want to scan on the copier glass.
2. At the Idle screen, press the menu button once to display the Functions menu.

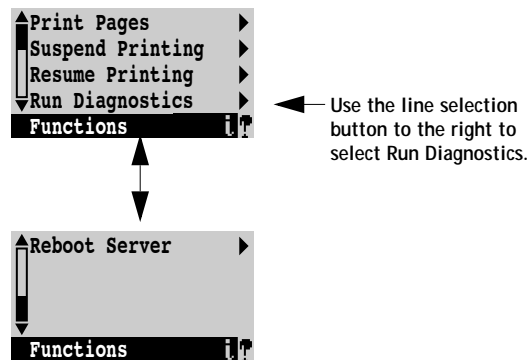

FIGURE 3-4 Run Diagnostics command in the Functions menu

3. Select Run Diagnostics from the Functions menu.
4. Select Test Scan/Print.

The message Scanning from copier and printing.... is displayed.

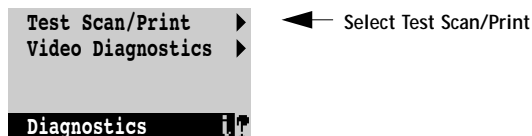

FIGURE 3-5 Test Scan/Print option

5. When the Fiery ZX is finished printing, compare the output from the copier to the original.

3

Installing additional options

Installing additional options

If the customer has purchased additional Fiery ZX options, install those before connecting the Fiery ZX to the network. For installation instructions, see the documentation included in each option kit.

After installing options, print a Test Page to verify that the system is operating properly. Checking the installation at each stage makes it easier for you to pinpoint the cause of problems should they occur.

NOTE: If the customer has purchased the Command Workstation hardware option, you can install it after you complete the Fiery ZX installation. For information on installing the Command WorkStation application from the CD, see the notes that came with the Fiery ZX.

Connecting to the network

The Ethernet network adapter chip built into the Fiery ZX motherboard provides connectivity to Ethernet networks. Supported Ethernet cabling includes: thinnet, thicknet, and twisted pair.

Other Fiery ZX connectivity includes a high-speed parallel port which enables the Fiery ZX to connect directly to the parallel port of a PC-compatible (see "Connecting a PC-compatible to the Fiery ZX" on page 3-11).

Token Ring compatibility is available with the optional Token Ring kit (see the documentation included with that kit for more information).

3

Connecting the Fiery ZX

Ethernet network connections

The motherboard in the Fiery ZX has two external Ethernet network connectors: an AUI (Attachment Unit Interface) connector for a thin Ethernet cable (thinnet) or a thick Ethernet cable (thicknet), as well as a 10BaseT/100BaseT connector for twisted pair (see Figure 3-6). For network configuration information, see the *Configuration Guide*.

NOTE: Only one Ethernet connection should be made to the Fiery ZX at a time.

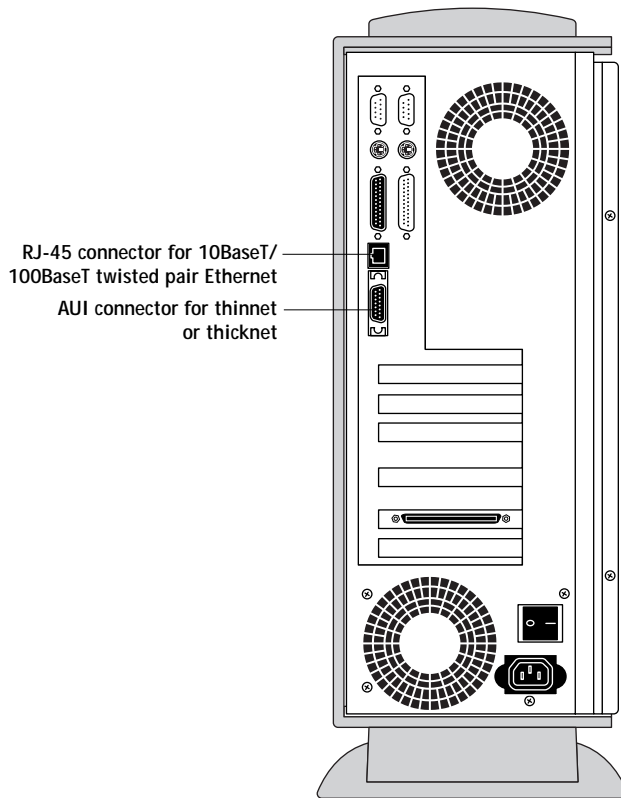

FIGURE 3-6 Fiery ZX network connectors

3

Connecting to the network

TO CONNECT A THINNET OR THICKNET CABLE TO THE FIERY ZX

Thinnet (thin coaxial Ethernet cable or 10Base2) connections require an external Ethernet transceiver attached directly to the AUI connector on the back of the Fiery ZX. An Ethernet transceiver is provided.

Thicknet (thick coaxial Ethernet cable or 10Base5) connections require an external Ethernet transceiver with an AUI drop cable connected to the AUI connector on the back of the Fiery ZX.

1. Power off the Fiery ZX before connecting it to any network device.
2. With the AUI slide latch in the down position, connect the network cable to the AUI connector on the back of the Fiery ZX. Slide the latch up to lock the connector in place.
 - To connect a thinnet cable to the Fiery ZX, an external Ethernet transceiver must be installed on the Fiery ZX AUI connector. The thinnet cable then connects to the BNC connector on the Ethernet transceiver.

If the Ethernet transceiver has an SQE switch, make sure the switch is set to Off.

- To connect a thicknet cable to the Fiery ZX, connect the AUI drop cable directly to the AUI connector on the back of the Fiery ZX.

NOTE: If you power on the Fiery ZX without connecting the network cable to the attached Ethernet transceiver, a Fiery ZX error may occur. Make sure the network cable is connected to the Ethernet transceiver before you power on the Fiery ZX.

3. Configure Setup options.

It is the network administrator's responsibility to configure Setup according to the network and user environment. Default settings in Setup are adequate although they may not be optimal for the user's environment. Refer the network administrator to the *Configuration Guide* for Setup information.

4. After configuring Setup options, verify the network connection.

Once the network connection has been made and the Fiery ZX has the correct Setup configuration, the Fiery ZX should be available on the network.

The network administrator should perform any additional network setup, verify the network connection, verify that the Fiery ZX appears on the list of printers, and print a few test documents from a networked computer that will use the Fiery ZX. (See the *Configuration Guide* for more information.)

3

Connecting the Fiery ZX

TO CONNECT A TWISTED PAIR CABLE TO THE FIERY ZX

Twisted pair (unshielded twisted pair cable or 10BaseT/100BaseT) uses an 8-pin, RJ-45 connector that connects to the back of the Fiery ZX (see Figure 3-6 on page 3-8).

1. Power off the Fiery ZX before connecting it to any network device.
2. Connect the network cable to the RJ-45 connector on the back of the Fiery ZX.
A Category 5 unshielded twisted pair cable (UTP) network cable must be used for 100BaseT.
3. Configure Setup options.
It is the network administrator's responsibility to configure Setup according to the network and user environment. Default settings in Setup are adequate although they may not be optimal for the user's environment. Refer the network administrator to the *Configuration Guide* for Setup information.

4. After configuring Setup options, verify the network connection.

Once the network connection has been made and the Fiery ZX has the correct Setup configuration, the Fiery ZX should be available on the network.

The network administrator should perform any additional network setup, verify the network connection, verify that the Fiery ZX appears in the list of printers, and print a few test documents from a networked computer that will use the Fiery ZX. (See the *Configuration Guide* for more information.)

3

Connecting a PC-compatible to the Fiery ZX

Connecting a PC-compatible to the Fiery ZX

The parallel connector on the back of the Fiery ZX provides a high-speed interface port that allows the Fiery ZX to connect directly to the parallel port of a PC-compatible. Although there are a number of PC-based devices that may be connected to the Fiery ZX for parallel printing, the procedure for connecting each of these device types is relatively similar.

The Fiery ZX connects to the parallel port of a PC-compatible through the parallel cable (10' long, with a female 25-pin D-sub connector on one end, and a 25-pin male D-sub connector on the other end). The parallel cable is shipped with the Fiery ZX.

TO CONNECT THE FIERY ZX TO A PC-COMPATIBLE

1. Power off the Fiery ZX.
2. With the network administrator's permission, power off the PC-compatible.
3. Connect the male 25-pin connector on the cable to the parallel port of the PC-compatible.

If there is more than one parallel port connector on the back of the PC-compatible, ask the network administrator to indicate the preferred parallel port to use for the Fiery ZX.

4. Connect the female 25-pin connector on the cable to the parallel port (labeled LPT1) on the back of the Fiery ZX (see Figure 3-7 on page 3-12).

3

Connecting the Fiery ZX

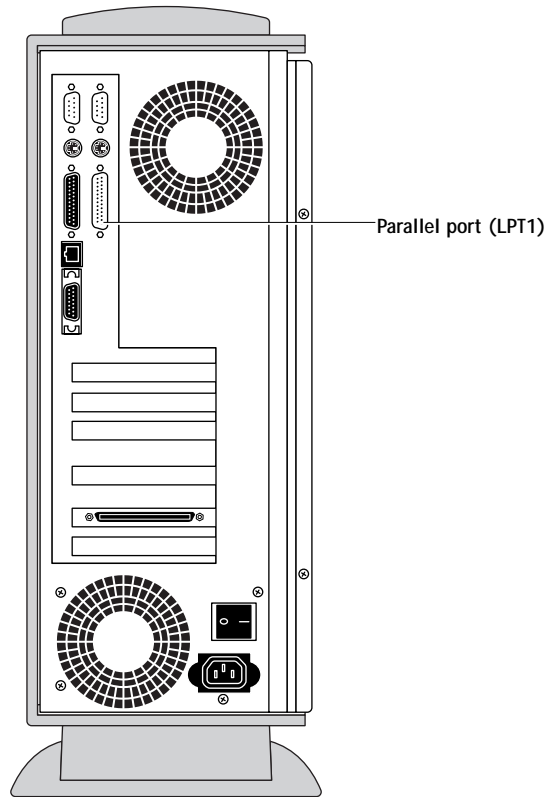

FIGURE 3-7 Parallel port (LPT1)

5. Power on the PC-compatible and the Fiery ZX.
6. Configure Setup options.

It is the network administrator's responsibility to configure Setup according to the network and user environment. Refer the network administrator to the *Configuration Guide* for Setup information.

7. After configuring Setup options, verify the connection.

Once the parallel port connection has been made and the Fiery ZX has the correct Setup configuration and has reached Idle, the network administrator should print a few test documents from the PC-compatible with the parallel (lpt) port connected to the Fiery ZX. (See the *Configuration Guide* for more information.)

3 Using the Control Panel

Using the Control Panel

This section describes the Control Panel on the front of the Fiery ZX. Once you install the Fiery ZX and verify that it powers up correctly, you can use the Control Panel to access and monitor different functions of the Fiery ZX.

The current status of the Fiery ZX and Setup information are displayed in the Fiery ZX display window. Fiery ZX activity can be monitored in the display window, and functions of the Fiery ZX (such as printing a Test Page and installing or updating system software) can be controlled using the buttons on the Control Panel.

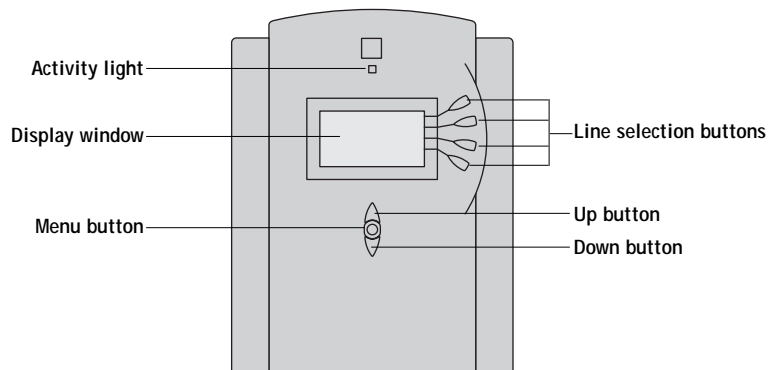

FIGURE 3-8 The Fiery ZX Control Panel

3

Connecting the Fiery ZX

Activity light

The activity light indicates current Fiery ZX activity. If the light is:

Solid red	There is an error causing printing to be disabled.
Flashing red	There is an error causing printing to be disabled, but the Fiery ZX is still processing. The light changes to solid red when it is finished processing.
Solid green	The Fiery ZX is idle.
Flashing green	The Fiery ZX is processing or printing a job, or communicating with a remote computer—for example, through Fiery Spooler.
No light	The Fiery ZX is off or starting up.

Buttons

Line selection buttons	There are four line selection buttons on the right side of the Control Panel. Use these buttons to select the command displayed on the corresponding line of the display window. A special character (>) appears in the display window next to a button when it is available.
Up and down buttons	Use these buttons to scroll to different screens in multi-screen lists, to select Setup options from a list, and to select alphanumeric characters.
Menu button	Press this button to view other display screens. There are several different display screens, showing different types of information about the Fiery ZX.

3 Using the Control Panel

Control Panel screens and icons

When the Fiery ZX is in Print mode, pressing the menu button cycles among four screens: three status screens (Info, RIP, and Print) and the Functions menu (see Figure 3-9). When the Fiery ZX is idle, pressing the menu button cycles between the Info screen and the Functions menu.

The bottom line of the screen displays the name of the current screen with the icon for that screen highlighted. Icons for other active screens are also displayed but are not highlighted.

The Fiery ZX screens display the following information:

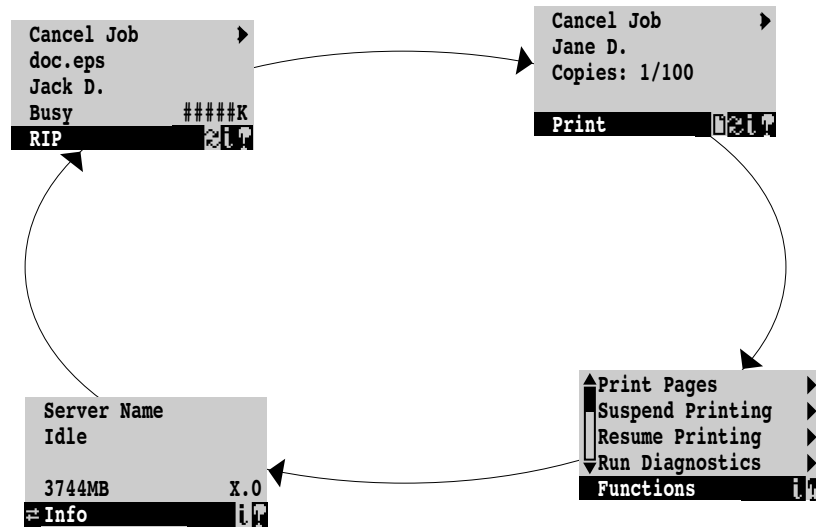

FIGURE 3-9 Control Panel screens during printing

If an error occurs, the Alert screen is displayed with a message describing the error.

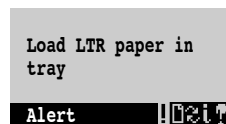





FIGURE 3-10 Alert screen

3 Connecting the Fiery ZX

The display window screens and icons are:

	Alert Status	If there is a problem during printing or processing, the Alert Status screen is activated, displaying an error message. For information on error messages, see the <i>Printing Guide</i> .
	Print Status	When the Fiery ZX is printing, the Print Status screen is activated. This screen displays the following: Cancel Job—Press the top line selection button to cancel the job currently printing. User name—The name of the user who sent the job that is currently being processed. Pages/Total—The number of copies of the current page that have been printed so far, and the total number of copies of this page that were requested.
	RIP Status	When the Fiery ZX is processing a job, the RIP Status screen is activated. This screen displays the following: Cancel Job—Press the top line selection button to cancel the job currently processing. The Fiery ZX cancels the job before printing begins. Document name—The name of the document currently processing. User name—The name of the user who sent the job that is currently being processed. Kilobytes—The amount in kilobytes of the job that has been processed so far.

3

Using the Control Panel



Info Status

The Info Status screen displays information about the server's current activity, and software version. This screen is always active, and it appears in the display window when no other screen is selected. It displays the following information:

Server Name—The Fiery ZX name as it is configured in Setup.

Status—The current status of the Fiery ZX. The Fiery ZX status can be: Idle, Initializing, Busy, Processing, or Printing.

Number of MB—The space in megabytes available on the Fiery ZX hard disk.

Version—The system software version running on the Fiery ZX.



Functions

The Functions screen also is always active, but it appears in the display window only when the user has pressed the Menu button to select it. Use the up and down buttons to scroll through the list of menu command options. Press the line selection button to the right of a command to select it.



Network

The Network icon appears in the bottom left corner of the display window when the Fiery ZX is communicating over the network. The Network icon can appear while any screen is displayed.

3

Connecting the Fiery ZX

Functions menu

The Functions menu allows you to perform a variety of administrative functions that do not affect print jobs of other users. Use the up and down buttons to scroll through the list of options. Press the line selection button next to the option you want to select.

The following options are available from the Functions menu:

Print Pages—Enables you to print special pages from the Fiery ZX. You can print the following pages from the submenu that appears:

- Test Page—Prints a Fiery ZX Test Page to the current print device. This enables you to confirm that the Fiery ZX is properly connected to the copier and to view information about color and grayscale to troubleshoot the Fiery ZX. The following information also displays: Fiery ZX server name, printer model, calibration information, date printed, default simulation, RGB source, rendering style, color mode, and compression information.
- Configuration—Prints the current server and device configuration. This includes information about all current Setup settings, calibration profile, and the Ethernet address of the Fiery ZX.
- Job Log—Prints the log of the last 55 jobs by default. For more information about the job log, see the *Printing Guide*.
- Control Panel Map—Prints the Setup screen help pages. These pages are useful when navigating through the different Setup screens.
- Color Charts—Prints the color reference charts. These pages include swatches of the RGB, CMY, and PANTONE colors available from the Fiery ZX.
- Font List—Prints a list of all the fonts resident on the Fiery ZX hard disk drive.

3

Using the Control Panel

Suspend Printing—Disconnects the Fiery ZX from the copier. This option interrupts the current print job so that you can use the copier to make copies; after you make the copies you can select Resume Printing and the copier continues processing and printing jobs.

Resume Printing—Connects the copier to the Fiery ZX so that you can resume printing after interrupting the print job to make copies (used with Suspend Printing).

Run Diagnostics—When you select this option, you can choose one of the following options:

- **Test Scan/Print**—Scans whatever is on the copier glass and prints out the image on letter size paper.
- **Video Diagnostics**—Runs diagnostics on the Fiery ZX video interface board.

Select the diagnostic test you want to run and press the line selection button next to OK. For more information, see Chapter 5 “Troubleshooting.”

Reboot Server—Shuts down all Fiery ZX activity properly and then restarts. You can also reboot the Fiery ZX using the reset button on the front panel.

3

Connecting the Fiery ZX

Shutting down and restarting the Fiery ZX

The Fiery ZX will generally be left on all the time at the customer site. Remember that when the Fiery ZX is powered off, network access to the copier is interrupted.

You should power off the Fiery ZX when you need to service it or the copier, and before you remove or attach any cables to the Fiery ZX. Power off the Fiery ZX when changing the copier's toner in order to prevent the fan from drawing toner into the Fiery ZX.

TO SHUT DOWN THE FIERY ZX

1. Make sure that the Fiery ZX Info screen reads **Idle**.

When **Printing** or **Ripping** appears on the Control Panel the Fiery ZX is currently processing. **Idle** appears in the Info screen when the Fiery ZX is finished processing the job.

2. Power off the Fiery ZX using the power switch on the back panel (press 0).

If the system has just finished processing, wait 5 seconds after the system reaches the idle state before using the power switch to shut down the unit.

NOTE: When you power off the Fiery ZX, make sure you also power off the copier or disconnect the copier interface cable that connects the Fiery ZX to the copier. Leaving the copier powered on and connected to the Fiery ZX while the Fiery ZX is powered off can lead to excessive drain on the Fiery ZX motherboard battery.

TO RESTART THE FIERY ZX

1. If the Fiery ZX is already on, ensure that it is not receiving, processing, or printing a document.

If **Printing** or **Ripping** appears on the Fiery ZX Control Panel, the Fiery ZX is currently processing a print job. Wait until the job is complete and **Idle** appears in the Info screen.

2. Press the menu button once, then select **Reboot Server** from the Functions menu. Otherwise, power on the Fiery ZX using the power switch on the back panel.

4

Overview

Chapter 4: Service Procedures

Generally, the Fiery ZX requires no regular service or maintenance. Use the procedures in this chapter to inspect, remove, reseal, and replace major hardware components as well as to install system software.

Overview

This chapter includes information on servicing the following components:

- Circuit boards
- Cables
- DIMMs (dual in-line memory modules)
- Battery
- Fans
- Power supply
- HDD (hard disk drive)
- CD-ROM drive
- Front panel components

See Figure 4-1 on page 4-2 for an overview of components. Replacement parts are available from your authorized service representative.



When performing the service procedures described in this chapter, follow the precautions listed in “Precautions” on page xiii.

NOTE: The tools required to service the system are listed in “Tools you will need” on page xv.

System software service

Fiery ZX system software is installed on the HDD at the factory. Use the system software service kit when you need to:

- Replace the HDD
- Replace the motherboard
- Upgrade to a more recent version of the system software

For information on how to install system software, see “Fiery ZX system software” on page 4-49.

4 Service Procedures

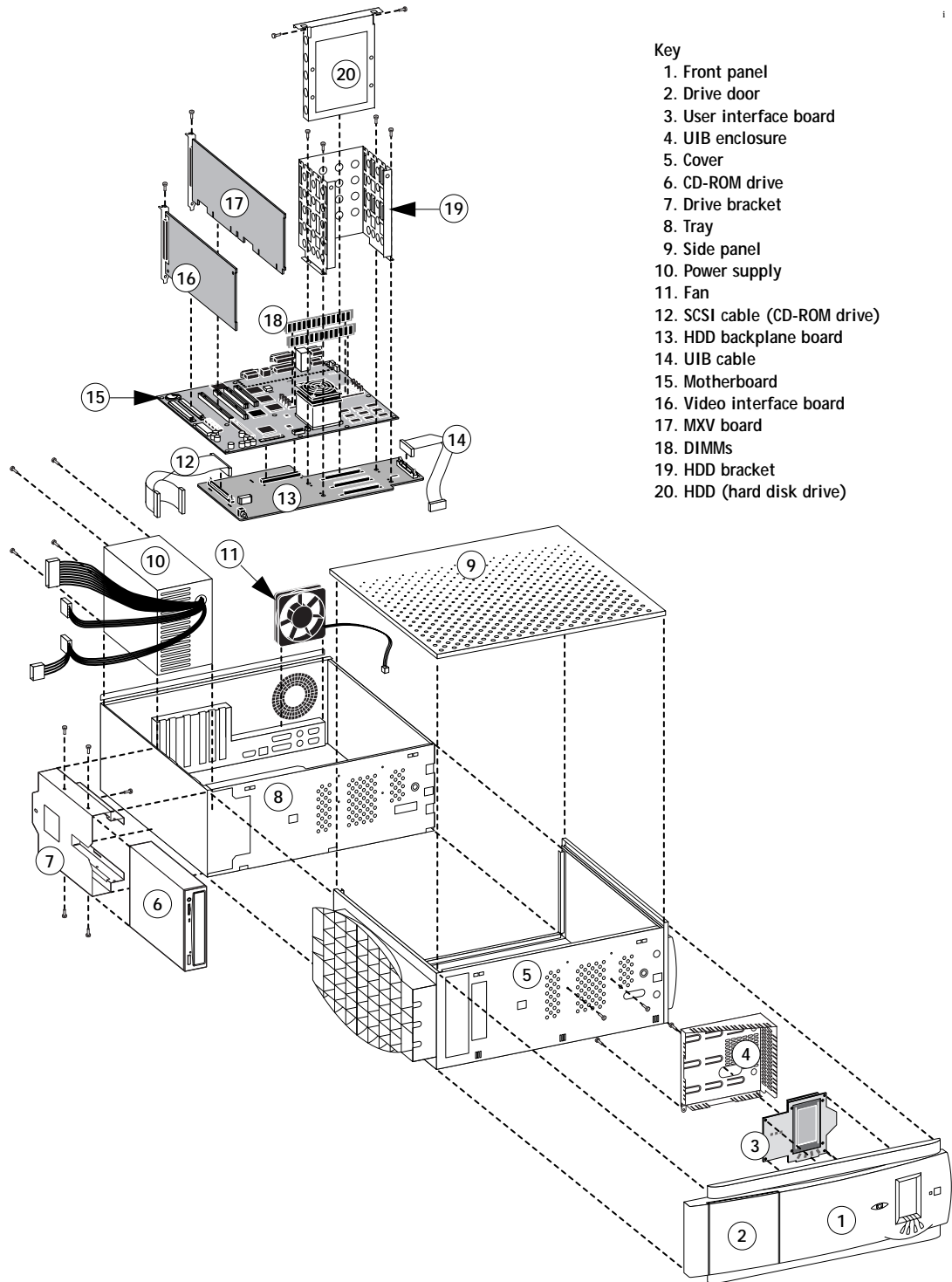

FIGURE 4-1 Exploded view of Fiery ZX components

4

Accessing Fiery ZX internal components

Accessing Fiery ZX internal components

Always use the procedure below when opening the Fiery ZX for inspection or service. If the Fiery ZX is powered on, shut down the system.

TO SHUT DOWN THE FIERY ZX



Always verify that the Fiery ZX is not being used before you power off or restart it. Make sure that the Fiery ZX is not ripping or printing a job.

1. Make sure the Fiery ZX Info screen reads Idle.
2. Power off the Fiery ZX using the power switch on the back.

If the system has just finished processing, wait 5 seconds after the system reaches the idle state before using the power switch to shut down the unit.

3. Disconnect all cables from the back of the Fiery ZX.

Always obtain permission from the network administrator before you take the Fiery ZX off the network.

TO OPEN THE FIERY ZX

1. Make sure you have shut down the Fiery ZX and removed all the cables from the back.
2. Loosen the two screws on the back of the Fiery ZX that secure the side panel to the tray.
3. Lift off the side panel (see Figure 4-2 on page 4-4).

4 Service Procedures

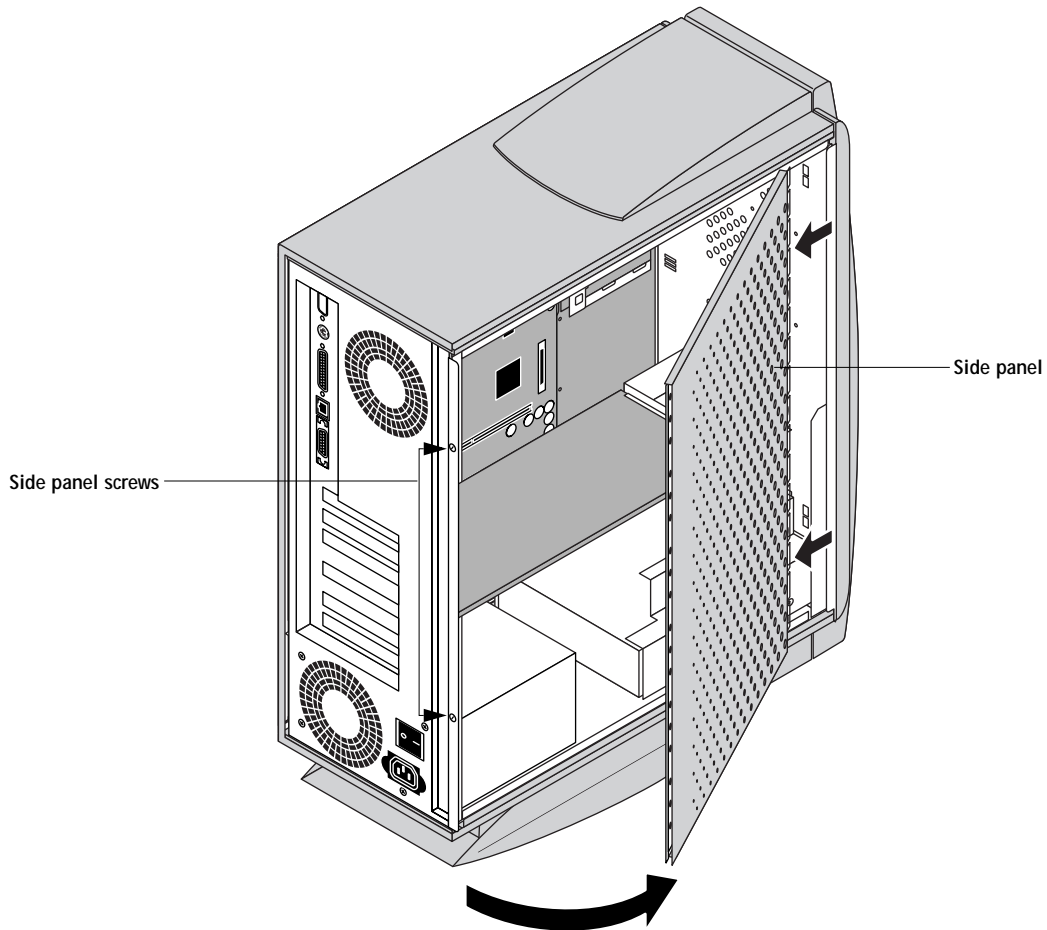

FIGURE 4-2 Removing the Fiery ZX side panel

4. The Fiery ZX internal components are now accessible. Attach an ESD wrist strap before handling internal parts.

The Fiery ZX is shipped from the factory with a standard board configuration, as shown in Figure 4-3 on page 4-5. If optional components have been installed, see the documentation that came with the specific kit.

NOTE: To service components inside the tray, position the Fiery ZX so that it is resting on its side and the components inside the tray are facing up.

4

Accessing Fiery ZX internal components

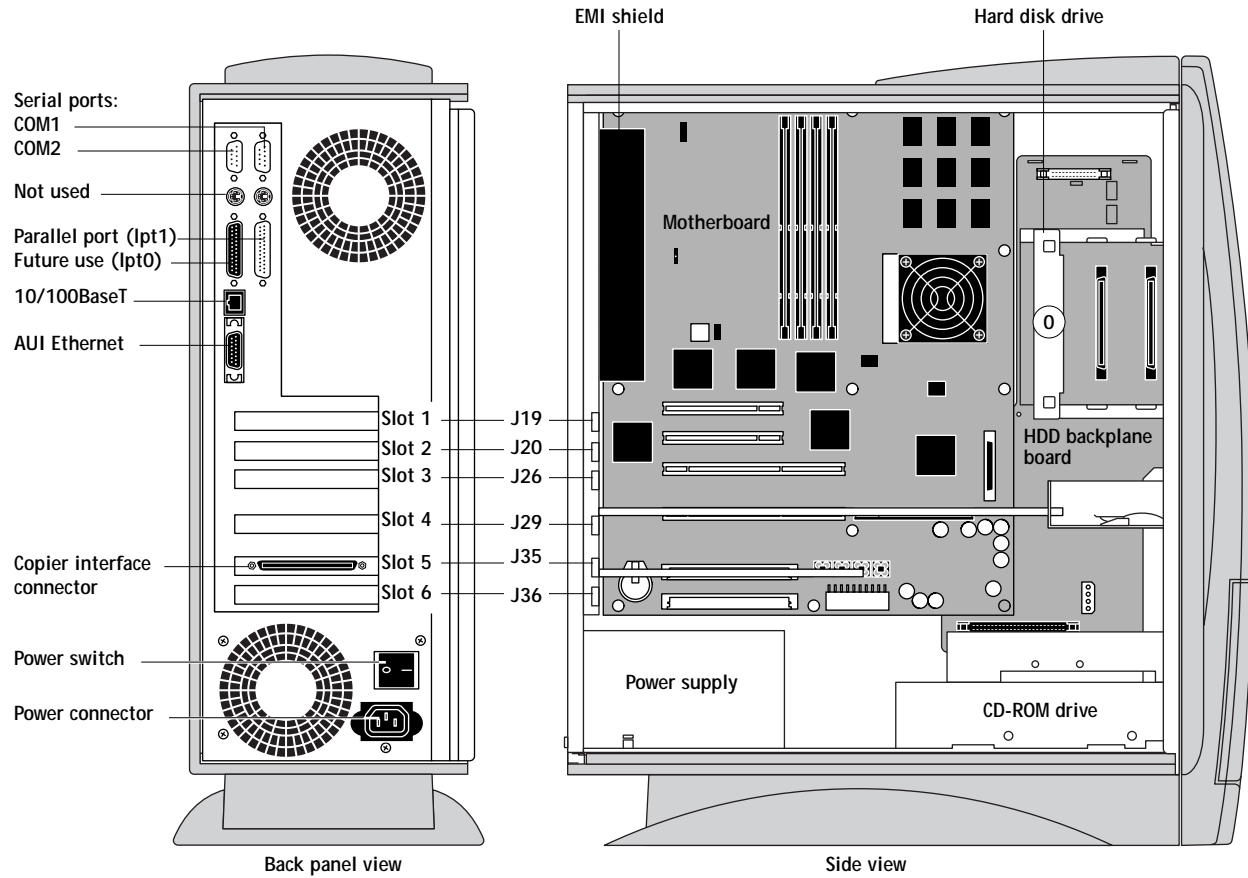

FIGURE 4-3 Fiery ZX side view and back panel view

4

Service Procedures

Accessing front panel components

The following procedure describes how to remove the front panel in order to access the user interface board, the Control Panel buttons, HDD bracket screws, and the top front panel jewel. You do not need to remove the front panel in order to access components inside the tray.

TO REMOVE THE FRONT PANEL

1. Remove the Fiery ZX side panel as described in "To open the Fiery ZX" on page 4-3.
2. Remove the UIB cable from the HDD backplane board.
The other end of the UIB cable is connected to the user interface board inside the front panel.
3. On the inside front of the tray, squeeze the tabs that secure the front panel to the tray.
4. As you squeeze the tabs, gently rotate the front panel to the right to release the hooks from the tray.
5. Thread the UIB cable connector through the opening in the front of the cover to completely remove the front panel.
The front panel components are now accessible.

4

Accessing Fiery ZX internal components

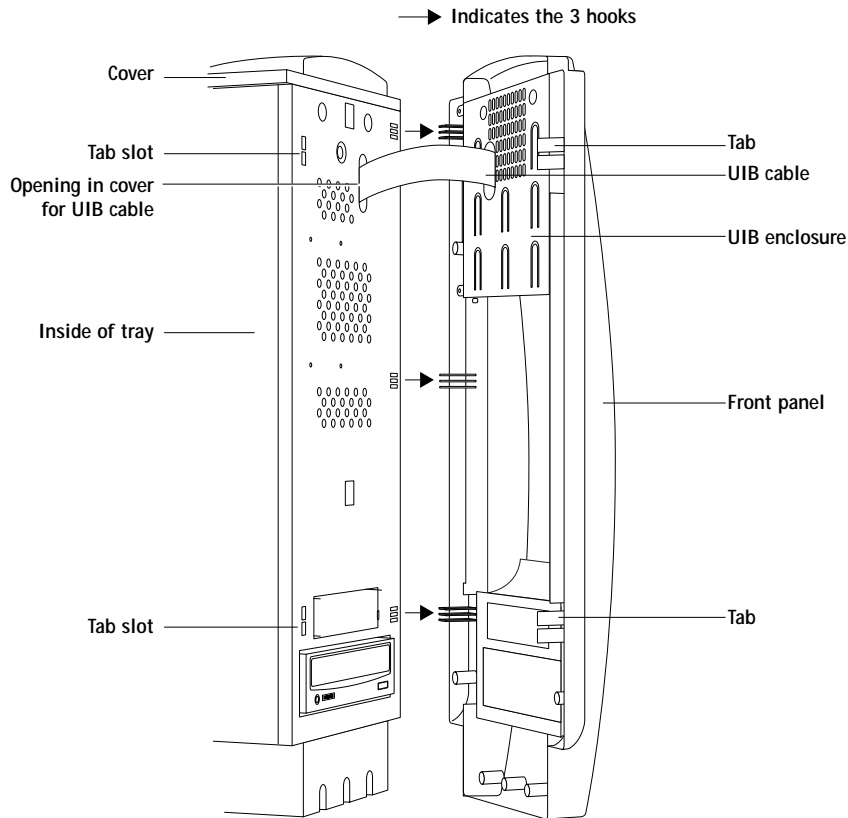

FIGURE 4-4 Removing the front panel

TO REPLACE THE FRONT PANEL

1. Make sure the UIB enclosure and all front panel components are installed correctly.
2. Thread the end of the UIB cable that connects to the HDD backplane board through the opening in the front of the cover.
The other end of the cable should already be securely connected to the user interface board.
3. Connect the UIB cable to connector J6 on the HDD backplane board.
When you connect the cable, be sure to snap the levers together to ensure that the connector is securely fastened.
4. Angle the front panel so that the three hooks on the edge of the front panel line up with the cutouts on the front of the cover (see Figure 4-4).
5. Rotate the front panel into the cover until you hear it snap into place.

4

Service Procedures

Checking Fiery ZX internal connections

The most common causes of hardware problems are faulty and loose connections. Before you conclude that any board or component has failed, remove, inspect, and reseal all appropriate connections, and then verify that the problem still occurs.

TO CHECK BOARD AND CABLE CONNECTIONS



1. Before you touch any parts inside the Fiery ZX, attach a grounding wrist strap. Touching the metal part of the power supply case inside the Fiery ZX also discharges static electricity.
2. Position the Fiery ZX so it is resting on its side and the internal components of the Fiery ZX are facing up.
3. Inspect the Fiery ZX boards for secure insertion into the motherboard. Press down firmly on each board to make sure it is securely installed.

Looking into the tray from the top, the standard board configuration includes the following (from top to bottom):

Connector J19—Empty

Connector J20—Empty

Connector J26—Empty

Connector J29—MXV board

Connector J35—Video interface board

Connector J36—Empty

4. Inspect the HDD for secure insertion into the HDD backplane board.
5. Inspect the motherboard connection to the HDD backplane board.
6. Inspect ribbon cables to see if they are intact.
Faulty ribbon cables are easily overlooked. Check the contact point between the cable and the connector to ensure that they have not separated. If a ribbon cable is suspect, substitute it with a tested cable.
7. Make sure that all Fiery ZX ribbon cables and power cables are seated on connectors. See Figure 4-5 on page 4-9.
Cable connectors are keyed to fit only when properly oriented.
8. Check the back panel fan and the CPU fan connections to the motherboard.
9. Make sure motherboard jumpers have the correct jumper configuration (see “Motherboard jumpers” on page 4-32).
10. After tightening connections, if one or more Fiery ZX components are still not getting power, see “Checking voltages” on page 4-38.

4

Accessing Fiery ZX internal components

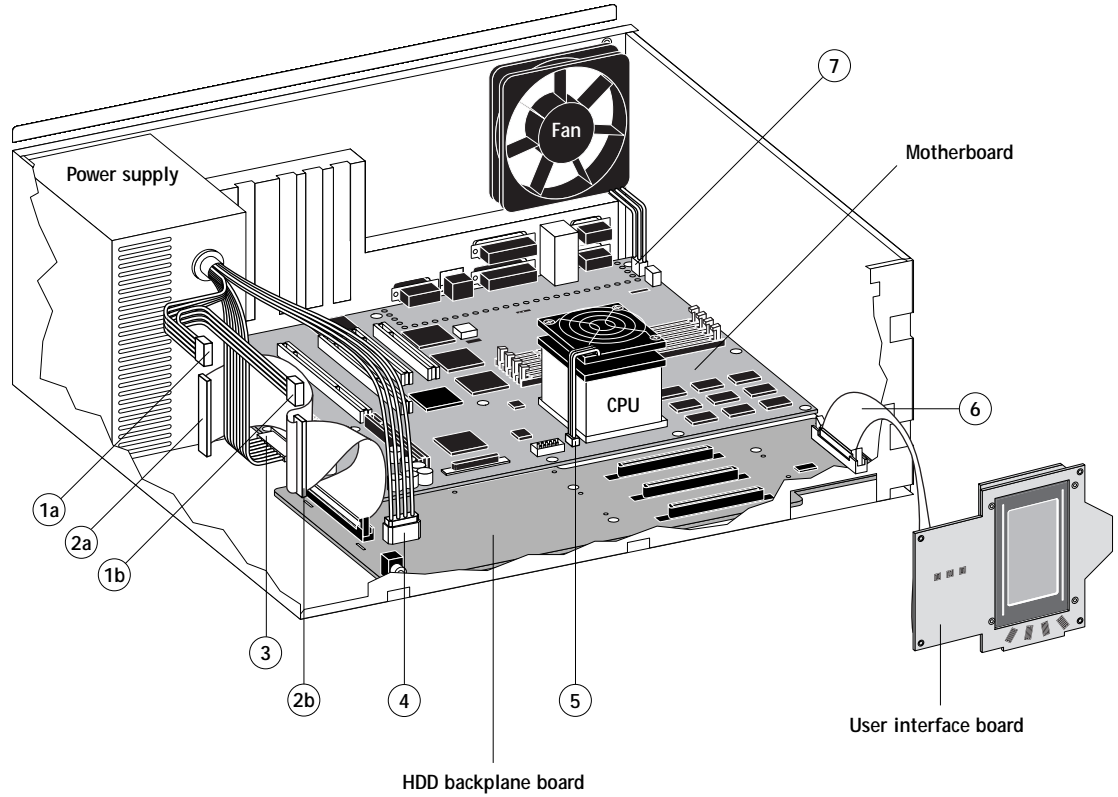

Cable key	From	To
1. Power supply cable	Power supply (4-pin large connector with a small 4-pin cable connector)	a. 4-pin large connector—CD-ROM drive b. 4-pin small connector—future options
2. SCSI cable	SCSI connector on the HDD backplane board (J1)	a. CD-ROM drive b. Future options
3. Power supply cable	Power supply (20-pin cable connector)	Power connector on the motherboard (J3)
4. Power supply cable	Power supply (4-pin large cable connector)	Power connector on the HDD backplane board (J2)
5. CPU fan cable	CPU fan	Fan connector on the motherboard (J21)
6. UIB cable	UIB connector on the HDD backplane board (J6)	User interface board (J1)

FIGURE 4-5 Cable connections in the Fiery ZX

4

Service Procedures

TO CHECK MOTHERBOARD DIMM CONNECTIONS

1. Check that all DIMMs are locked. If any DIMMs have come loose, release and reseal them.
The DIMMs (dual in-line memory modules) on the Fiery ZX motherboard are held in place by levers at each end. Sockets J44-J47 on the motherboard hold the DIMMs.
2. To release a DIMM, push outward on the levers on each side of the DIMM.

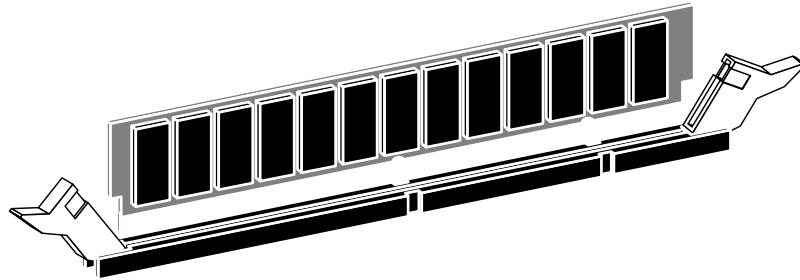

FIGURE 4-6 Releasing the DIMM levers

3. Slide the DIMM straight out of the socket.
4. To replace a DIMM, gently slide the DIMM straight into the socket and close the levers at each side to lock it into place.

Make sure that the levers close securely around the ends of the DIMM and that each DIMM is fully seated in its socket.

If you removed the DIMMs completely, note that DIMMs fit the socket only one way. The notches on the bottom of the DIMM should line up with the notches in the socket.

4

Accessing Fiery ZX internal components

Restoring Fiery ZX functionality after service

TO REASSEMBLE THE FIERY ZX

1. Reseat all boards, cables, connectors, and other parts loosened during inspection or service.
2. Place the Fiery ZX in its standard operating position.
3. If you removed the front panel, replace it (see "To replace the front panel" on page 4-7).
4. Place the side panel onto the Fiery ZX so the grooves on the edge of the side panel fit into the grooves in the tray (see Figure 4-7).

Be careful not to damage any ribbon cables; fold the ribbon cables inside the tray before replacing the side panel.

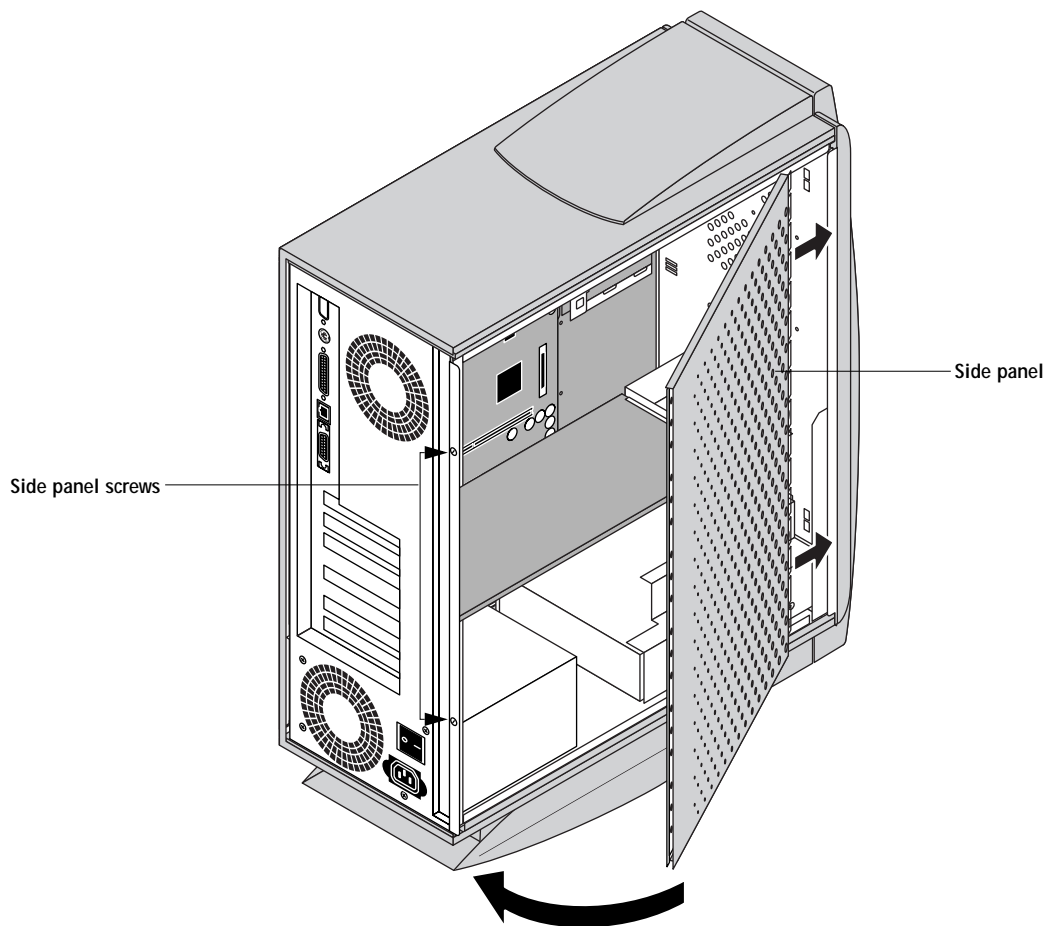

FIGURE 4-7 Replacing the side panel

4 Service Procedures

5. Tighten the two screws that secure the side panel to the cover.

NOTE: Do not leave the Fiery ZX side panel off after servicing. An airflow channel is created by the side panel and the fan. Leaving the Fiery ZX open for extended periods of time could reduce the operational life expectancy of internal Fiery ZX components.

6. Connect any cables removed during service to the back of the Fiery ZX.
7. Before you leave the customer site, verify Fiery ZX operation as outlined in Figure 4-8.

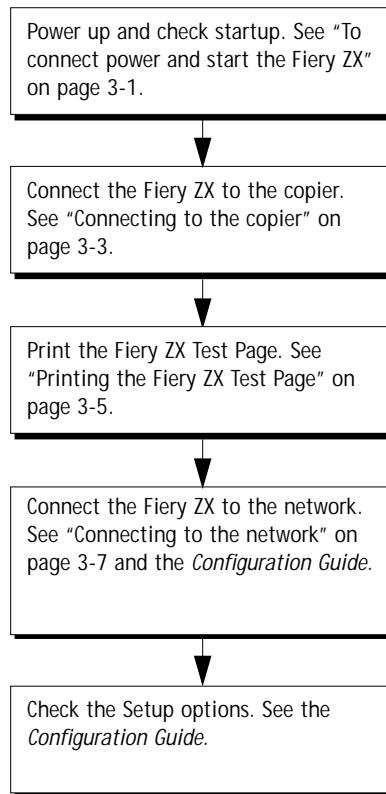

FIGURE 4-8 Fiery ZX connection verification steps

4

Accessing Fiery ZX internal components

Removing and replacing circuit boards

This section includes procedures for removing and replacing the following circuit boards:

- MXV board
- Video interface board
- STARR daughter card
- User interface board
- Motherboard
- HDD backplane board

For information on installing option boards, see the separate installation instructions that came with that board.

MXV board

The MXV board in the Fiery ZX (see Figure 4-9) is installed in connector J29 on the motherboard.

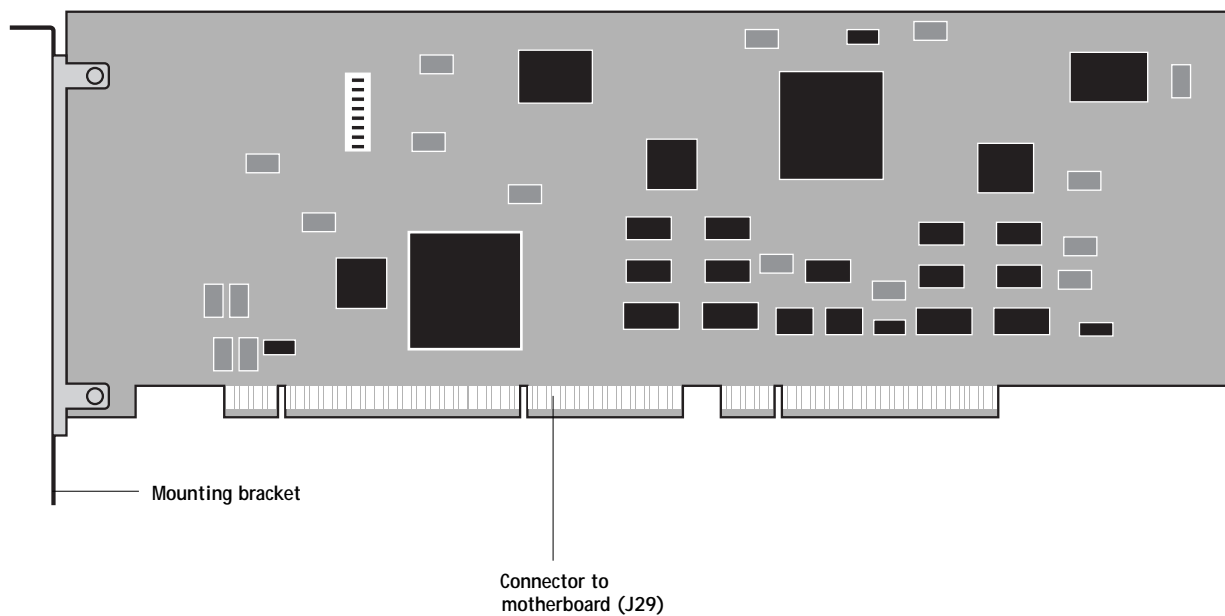

FIGURE 4-9 Diagram of the MXV board

4

Service Procedures

TO REMOVE THE MXV BOARD

1. Shut down and open the Fiery ZX as described in "To shut down the Fiery ZX" on page 4-3 and "To open the Fiery ZX" on page 4-3.
2. Remove the mounting bracket screw from slot 4.
3. If a tie wrap is attached to the edge of the MXV board and the board guide, cut it. The tie wrap is included for stability during shipping and does not need to be replaced.
4. Remove the MXV board from motherboard connector J29.

NOTE: You may need to angle the MXV board or remove the video interface board in order to remove the MXV board from the tray.

Grasp the board at the front and back edge. Gently rock the board backward and forward as you pull on it, until it releases from the motherboard.

5. Place the board in an antistatic bag.

TO REPLACE THE MXV BOARD

1. Slide the MXV board into connector J29 on the motherboard so that the right edge of the board fits in the board guide on the tray and the left edge fits in slot 4. The component side of the board faces down in the direction of the power supply.

The MXV board connector is keyed to fit only one way when properly oriented.

NOTE: You may need to angle the board in order to fit it into the tray.

2. Attach the board mounting bracket screw to the MXV board bracket in slot 4.
3. Reassemble the Fiery ZX and verify its functionality (see the connection verification steps described in "Restoring Fiery ZX functionality after service" on page 4-11).

4

Accessing Fiery ZX internal components

Video interface board

The video interface board in the Fiery ZX (see Figure 4-10) provides the interface between the Fiery ZX and the copier.

The copier interface connector on one side of the board (slot 5 on the back panel of the Fiery ZX tray) connects to a cable that plugs into the copier. The other connector on the video interface board attaches to the motherboard connector at J35.

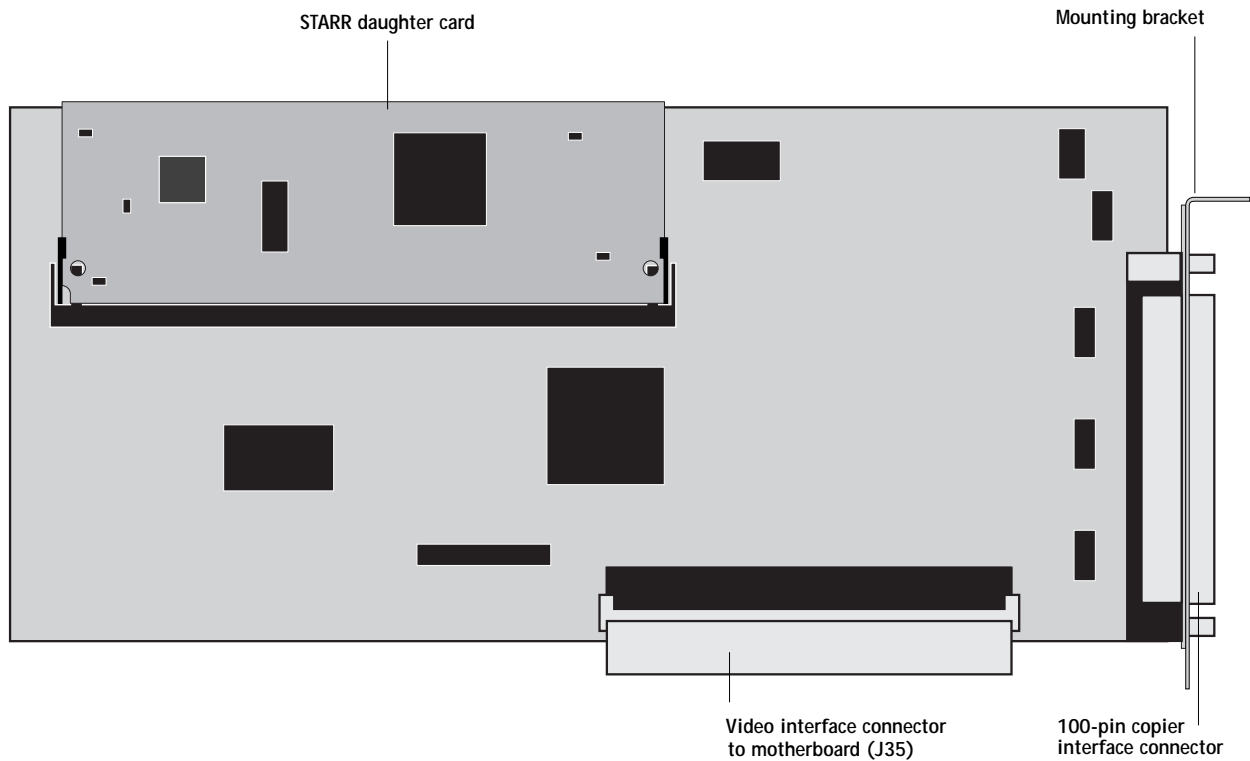

FIGURE 4-10 Diagram of the video interface board

4

Service Procedures

TO REMOVE THE VIDEO INTERFACE BOARD

1. Shut down and open the Fiery ZX as described in "To shut down the Fiery ZX" on page 4-3 and "To open the Fiery ZX" on page 4-3.
2. Make sure the copier interface cable connected to the back of the Fiery ZX is removed.
3. Remove the video interface board mounting bracket screw from slot 5.
4. Remove the video interface board from motherboard connector J35.
Grasp the board at the front and back edge. Gently rock the board backward and forward as you pull on it, until it releases from the motherboard.
5. Place the board in an antistatic bag.

TO REPLACE THE VIDEO INTERFACE BOARD

1. Reseat the video interface board in connector J35 on the motherboard with the components facing up.
The video interface board connector is keyed to fit only one way when properly oriented. Make sure that none of the connector pins are bent. Gently straighten any bent pins with a pair of needlenose pliers.
2. Attach the board mounting bracket screw to the video interface board bracket in slot 5.
3. Reassemble the Fiery ZX and verify its functionality (see the connection verification steps described in "Restoring Fiery ZX functionality after service" on page 4-11).
4. Make sure to attach the copier interface cable.

4

Accessing Fiery ZX internal components

STARR daughter card

The STARR daughter card is installed in connector J3 on the video interface board. It is responsible for decompressing the image data as it is sent from the Fiery ZX to the copier.

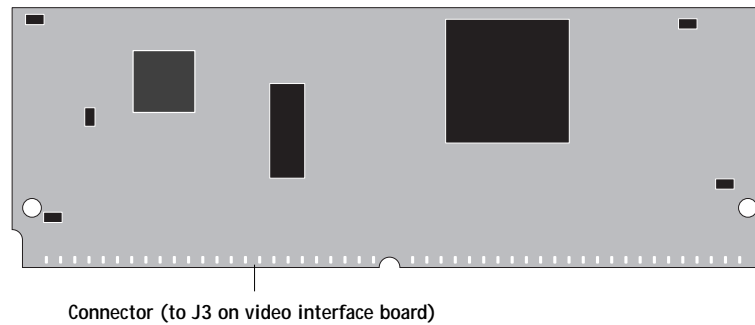

FIGURE 4-11 Diagram of the STARR daughter card

TO REMOVE THE STARR DAUGHTER CARD

1. Shut down and open the Fiery ZX as described in "To shut down the Fiery ZX" and "To open the Fiery ZX" on page 4-3.
2. Gently, pull out the clips on the video interface board around the edges of the STARR daughter card (see Figure 4-12 on page 4-18).
3. Slide the STARR daughter card out of connector J3 at a 45-degree angle.

4 Service Procedures

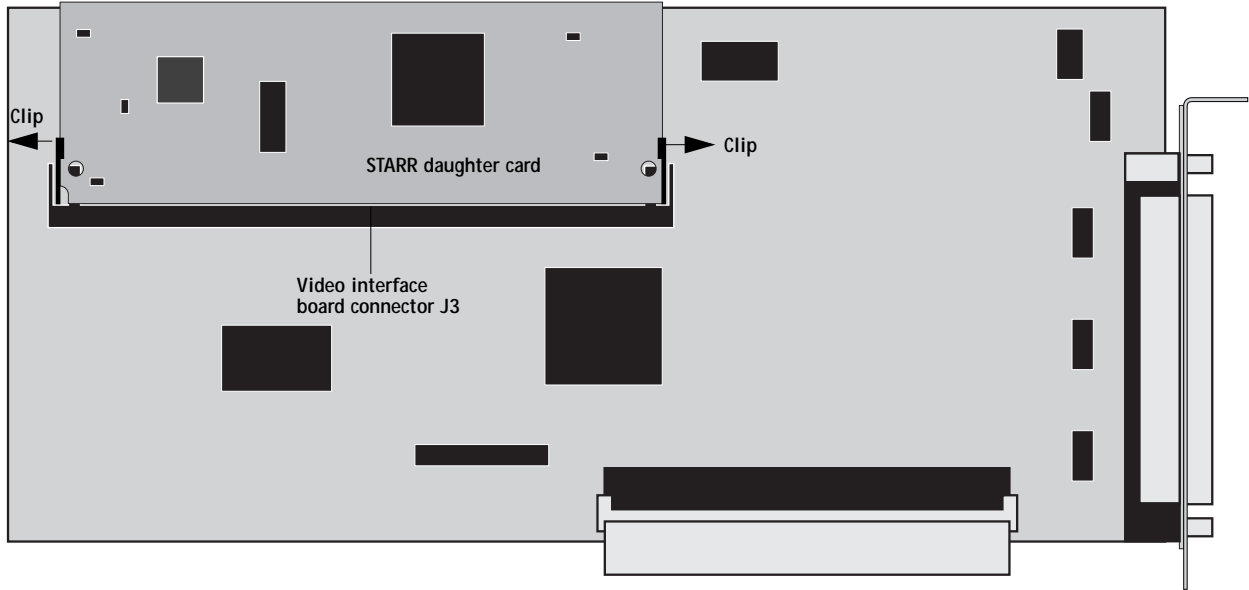

FIGURE 4-12 Removing the STARR daughter card

4

Accessing Fiery ZX internal components

TO REPLACE THE STARR DAUGHTER CARD

1. Slide the STARR daughter card into connector J3 on the video interface board at a 45-degree angle (see Figure 4-13).

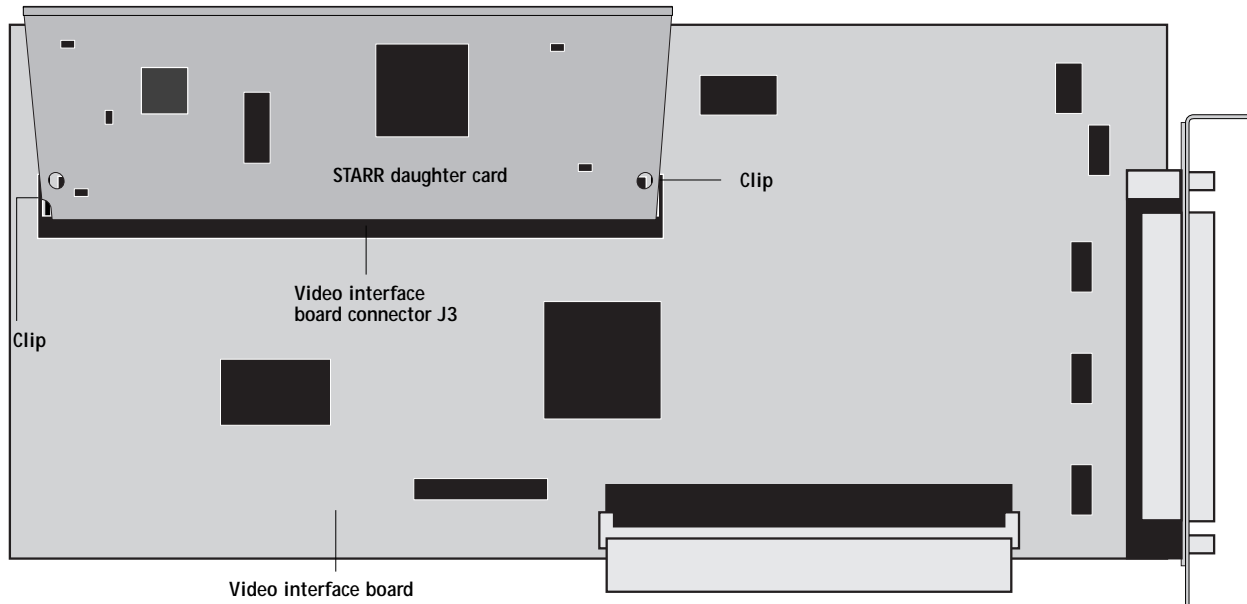

FIGURE 4-13 Installing the STARR daughter card

2. Push the STARR daughter card down to lock it into place.
Make sure that the daughter card snaps into the connector clips and that the connector clips close securely around the card.
3. Reassemble the Fiery ZX and verify its functionality (see the connection verification steps described in "Restoring Fiery ZX functionality after service" on page 4-11).
4. Make sure to attach any cables that may have been removed during installation.

4 Service Procedures

User interface board

The user interface board installed in the front panel of the Fiery ZX (see Figure 4-14) provides an interface between the Fiery ZX server and the user. The front of the user interface board contains circuitry for the following:

- Activity lights (1 green and 1 red LED) at the top of the board
- Display window (LCD)
- Four line selection buttons
- Up and down buttons
- Menu button between the up and down buttons

A cable connector on the back of the board connects the user interface board to the HDD backplane board.

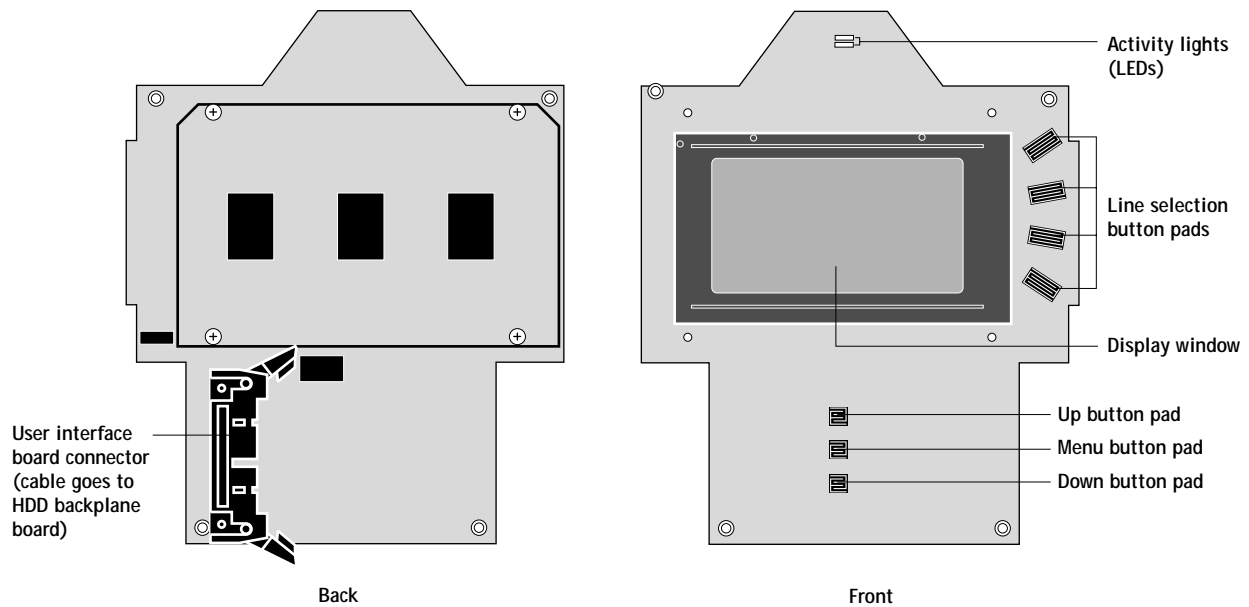

FIGURE 4-14 Diagram of the user interface board (back and front)

4

Accessing Fiery ZX internal components

TO REMOVE THE USER INTERFACE BOARD

1. Shut down the Fiery ZX as described in "To shut down the Fiery ZX" on page 4-3.
2. Remove the front panel from the Fiery ZX cover as described in "To remove the front panel" on page 4-6.

Make sure the UIB cable is disconnected from the HDD backplane board.

3. Remove the two screws that secure the UIB enclosure to the front panel.

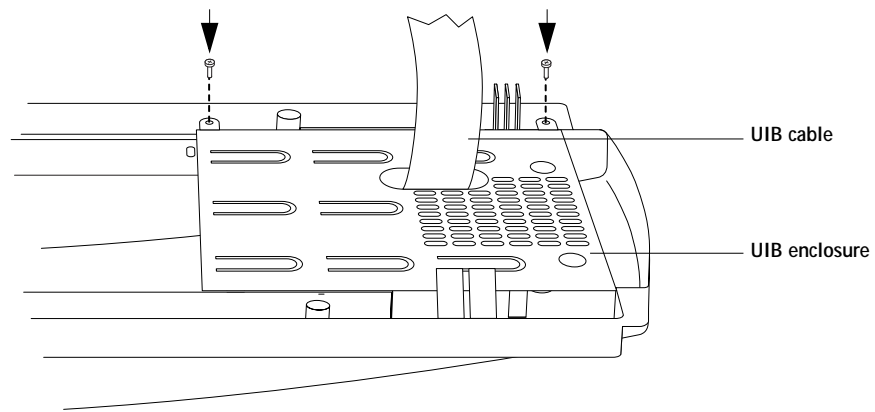

FIGURE 4-15 Removing the UIB enclosure

4. Carefully lift off the UIB enclosure. Thread the disconnected end of the UIB cable through the slot in the enclosure.
5. Disconnect the UIB cable from the connector on the user interface board and set the cable aside.

Press outward on the connector levers on each side of the connector (see Figure 4-16), then pull the connector free. Avoid pulling on the cable itself.

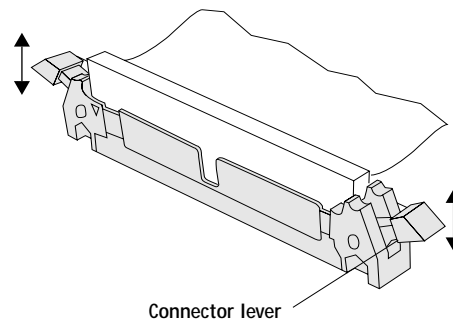

FIGURE 4-16 Detail of ribbon cable connector

6. Gently push outward on the snap tabs that secure the user interface board to the inside of the front panel.

4 Service Procedures

7. While pushing outward on the snap tabs, lift up one side of the user interface board and slide it out of the hooks (see Figure 4-17). Place the board in an antistatic bag.

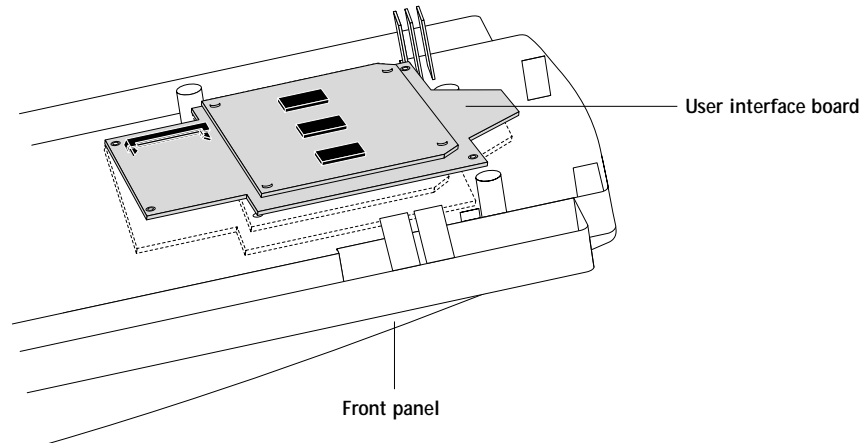

FIGURE 4-17 Removing the user interface board

TO REPLACE THE USER INTERFACE BOARD

1. Place the user interface board in the front panel at an angle so that the edge of the board fits under the front panel hooks (see Figure 4-17).
The board should be positioned so that the button pads on the front of the board line up with the buttons installed in the front panel.
2. Gently push the board into the snap tabs until it is securely seated in the front panel.
3. Attach the UIB cable to connector J1 on the user interface board.
When you connect the cable, be sure to snap the levers together to ensure that the connector is securely fastened.
4. Thread the UIB cable through the slot in the UIB enclosure.
5. Place the UIB enclosure over the user interface board and secure it with the two screws (see Figure 4-15 on page 4-21).
The edges of the UIB enclosure should fit inside the grooves in the front panel.
6. Replace the front panel as described in "To replace the front panel" on page 4-7.
7. Reassemble the Fiery ZX and verify its functionality (see the connection verification steps described in "Restoring Fiery ZX functionality after service" on page 4-11).

4 Motherboard

Motherboard

The custom Fiery ZX motherboard has an Alpha 21164 533MHz CPU chip that controls the image data transferred to and from the video interface board. The motherboard also controls HDD functions and the communication between the Fiery ZX and external devices. The motherboard has 4 DIMM sockets that hold 16, 64, or 128MB DIMMs (see page 4-29). The motherboard also includes:

- Two 32-bit PCI connectors (5 volt)
- Two 64-bit PCI connectors (3.3 volt)
- Two video DIN connectors

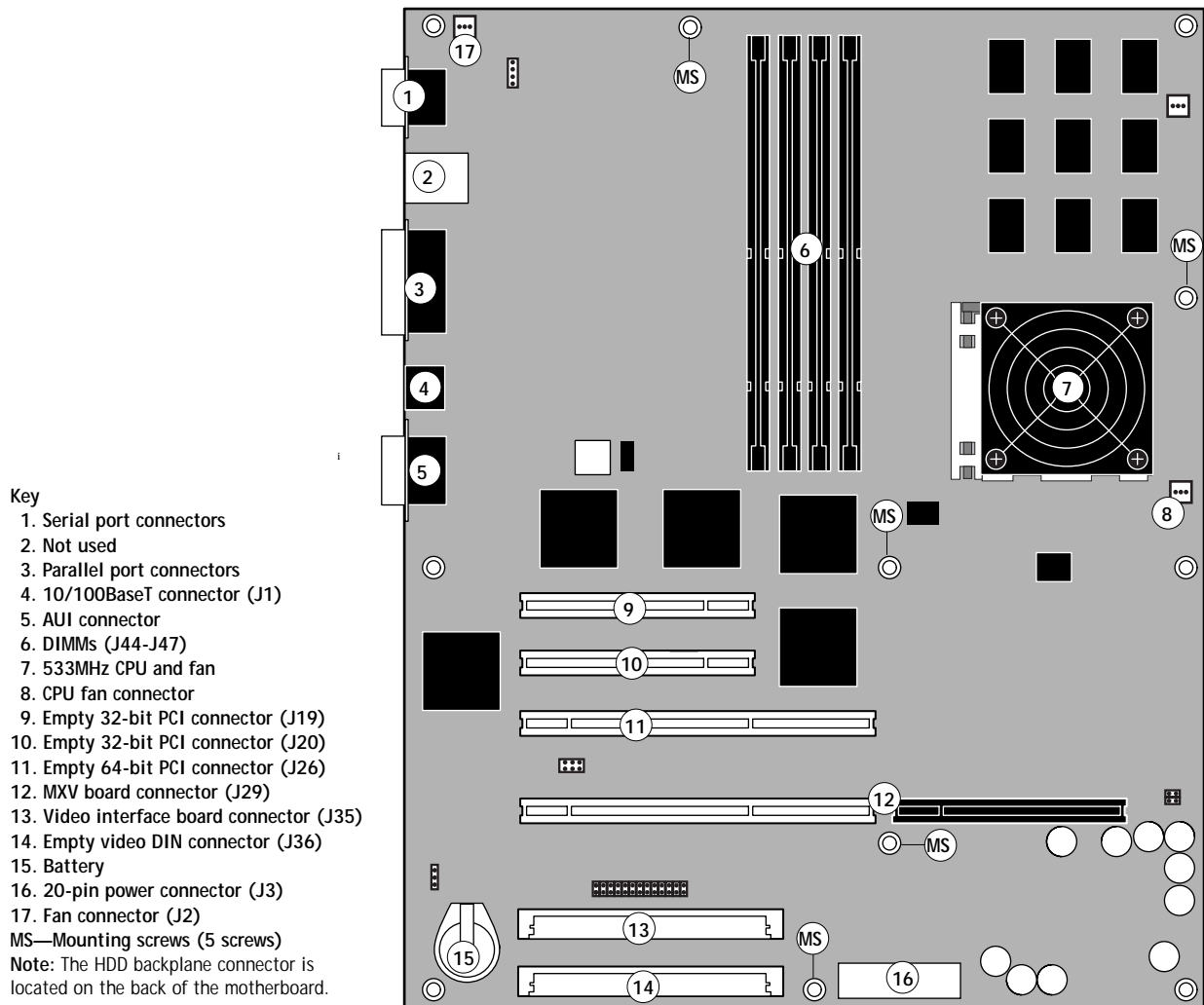

FIGURE 4-18 Diagram of the Fiery ZX motherboard

4

Service Procedures

Removing the Fiery ZX motherboard

The motherboard attaches to the side of the Fiery ZX tray above the power supply. Before you remove the motherboard, you must remove:

- All circuit boards installed on the motherboard
- Power and fan cable connectors to the motherboard
- Mounting hardware on back panel motherboard connectors

Instructions are included in this section for each of the procedures listed above. This section also includes information on replacing the battery, and DIMMs on the motherboard, as well as information on motherboard jumper configurations.

Take ESD precautions and be very careful when handling the Fiery ZX circuit boards.

TO REMOVE THE CIRCUIT BOARDS

1. Shut down the Fiery ZX and remove the side panel as described on page 4-3.
2. Remove the board mounting bracket screw in slot 5 for the video interface board.
3. Remove the video interface board from connector J35 on the motherboard.
Place the board on a static-free surface.
4. Remove the board mounting bracket screw in slot 4 for the MXV board.
5. Remove the MXV board from connector J29 on the motherboard.
Place the board on a static-free surface.

If a tie wrap is attached to the edge of the MXV board and the board guide, cut it. The tie wrap is included for stability during shipping and does not need to be replaced.

6. Remove the mounting bracket screws and any boards installed in connectors J19, J20, J26, or J36 on the motherboard.
Grasp the board at the top front and rear edges. Rock the board forward and backward as you pull on it until it lifts free. Place the boards on a static-free surface.

TO REMOVE MOTHERBOARD CABLES

1. Remove the 20-pin power connector at J3 on the motherboard (near the bottom of the motherboard).
2. Remove the fan cable connected to motherboard fan connector J2.

4 Motherboard

TO REMOVE THE MOTHERBOARD

1. Using a hex nut driver, remove the standoffs on the two serial port connectors and the two parallel port connectors on the back of the Fiery ZX.

Set the standoffs aside so they can be replaced later.

2. Remove the two screws and the latch on the AUI connector. Note the orientation of the latch so it can be replaced correctly later (see Figure 4-19).

To remove the screws, push the latch up to access the top screw and down to access the bottom screw.

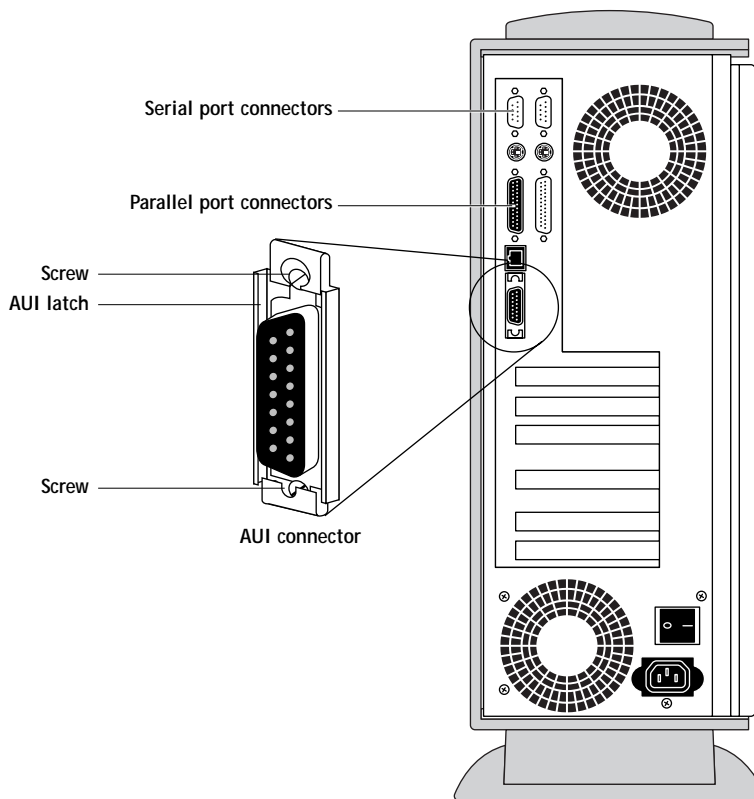

FIGURE 4-19 Motherboard back panel mounting hardware

3. Remove the five mounting screws on the motherboard (see Figure 4-18 on page 4-23 for locations).

If the plastic standoffs around the motherboard mounting holes come loose, be sure to set them aside so they can be replaced later (not included in later models).

4 Service Procedures

4. Push outward on one of the tray clips around the edge of the motherboard and then gently lift up that edge of the motherboard to release it (see Figure 4-20).

The two tray clips around the edges of the motherboard secure the motherboard to the tray. Note that three smaller tray clips are located on the tray near the back panel connectors.

5. Push outward on the other motherboard tray clip and then lift up that edge of the motherboard to release it (see Figure 4-20).
6. Lift up the edge of the motherboard opposite the back panel connectors to completely release the motherboard from the HDD backplane board.

The HDD connector on the back of the motherboard is connected to the HDD backplane board at connector P1.

7. Gently slide the motherboard out of the Fiery ZX tray (see Figure 4-20).

Make sure the back panel connectors on the motherboard clear the tray as you remove the board. Be careful to avoid handling contacts and avoid using excessive force.

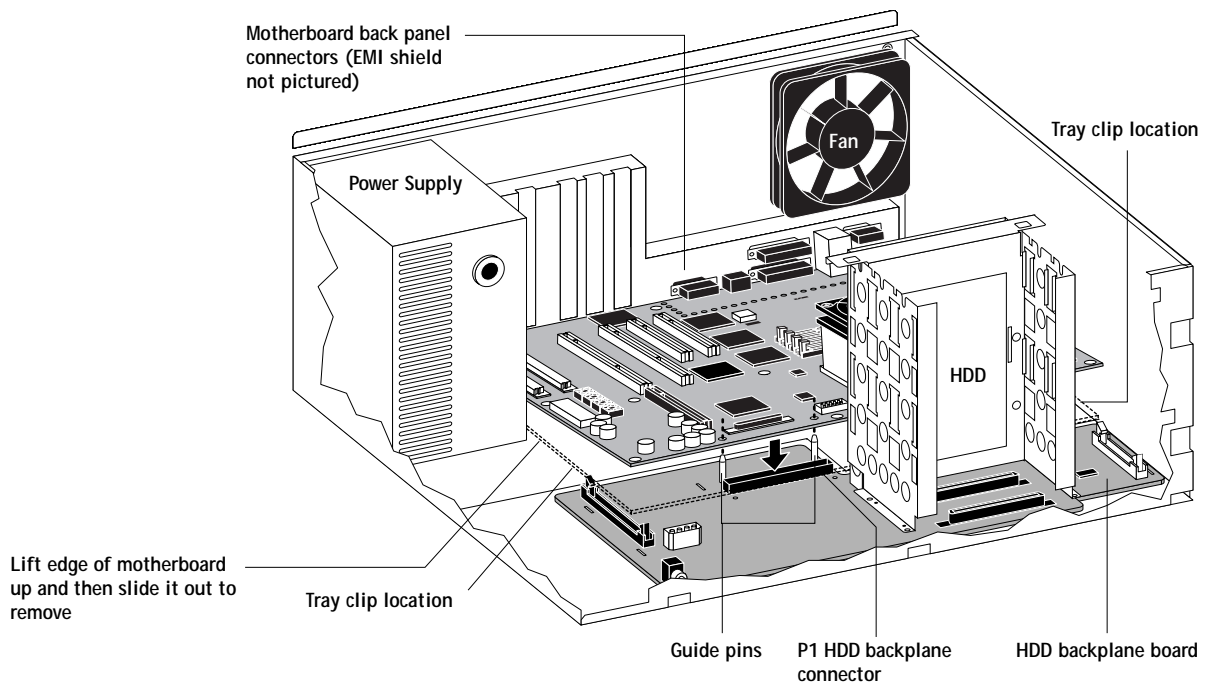

FIGURE 4-20 Removing the motherboard

4

Motherboard

Replacing the motherboard

This section includes the procedures required to replace the Fiery ZX motherboard.

TO REPLACE THE MOTHERBOARD

1. Make sure the plastic standoffs are in place on the motherboard mounting holes at the base of the Fiery ZX tray (some models do not include the plastic standoffs).
2. Loosen the four screws that attach the HDD bracket to the HDD backplane board.
This allows some flexibility when aligning the motherboard HDD backplane connector with the connector P1 on the HDD backplane board.
3. Angle the motherboard so that the back panel connectors on the motherboard fit into the cutouts in the back of the tray, and the edge of the motherboard fits underneath the three tray clips. See Figure 4-20 on page 4-26.
4. Align the guide holes in the motherboard with the guide pins located on either side of connector P1 on the HDD backplane board (see Figure 4-20 on page 4-26).
5. Once the guide holes in the motherboard are aligned over the guide pins, gently push the motherboard down to connect it to the HDD backplane board.
As you connect the motherboard to the HDD backplane board, the two tray clips close around the edge of the motherboard.

NOTE: Misalignment of these connectors could damage the power supply. If you suspect that the connectors are not aligned properly, connect the power cable to the motherboard and use a multimeter to check the blue and black wires on the connector. If the multimeter indicates a short, disconnect the motherboard from the HDD backplane and try again.
6. Insert the five motherboard mounting screws to attach the motherboard to the tray but do not tighten them completely (see Figure 4-18 on page 4-23 for screw locations).
7. Replace the standoffs in the serial and parallel connectors on the back of the Fiery ZX.
8. Replace the top screw in the AUI connector and tighten it completely.
9. Place the latch over the AUI connector and replace the second screw.
Make sure the latch is oriented as shown in Figure 4-19 on page 4-25. Push the latch up to secure the bottom screw.
10. Tighten the five motherboard mounting screws.

4

Service Procedures

TO REPLACE CIRCUIT BOARDS

1. Reseat the MXV board in connector J29 on the motherboard.
2. Reseat the video interface board in connector J35 on the motherboard.
Slide the board straight into the board guide. As you plug the board into the connector on the motherboard, make sure that the board connector is properly aligned with the connector on the motherboard. The video interface board is keyed to fit only one way on the motherboard so that it cannot be plugged in wrong.
3. Reseat any boards installed in connectors J19, J20, J26, or J36 on the motherboard.

TO REPLACE THE MOTHERBOARD CABLES

1. Connect the 20-pin power cable to connector J3 on the motherboard (at the bottom of the motherboard).
2. Connect the fan cable to the motherboard fan connector at J2.
The board fan connector is keyed to fit only when properly oriented.

TO COMPLETE AND VERIFY MOTHERBOARD INSTALLATION

1. Attach the board mounting bracket screws for boards installed in slots J19, J20, J26, J29, J35, and J36. Press down firmly on the top of the board as you insert each screw.
NOTE: Make sure unused slots have slot covers installed. Uncovered slots reduce air flow and could cause the Fiery ZX to overheat.
2. Press down on each cable connector and verify that all cables are attached properly.
3. Make sure the motherboard is securely connected to the HDD backplane board and that the connectors are properly aligned.
4. Check motherboard jumper settings for J30. See "Motherboard jumpers" on page 4-32.
5. Reassemble the Fiery ZX and verify functionality (see the connection verification steps described in "Restoring Fiery ZX functionality after service" on page 4-11).
6. Install system software (see "Fiery ZX system software" on page 4-49).

Replacing parts on the motherboard

This section describes how to remove and replace DIMMs and the battery on the motherboard. Before performing any of these procedures, you must first shut down the Fiery ZX as described in "To shut down the Fiery ZX" on page 4-3, and remove the side panel as described in "To open the Fiery ZX" on page 4-3.

For information on replacing the fan on the CPU, see "CPU fan" on page 4-37.

4 Motherboard

DIMMs

The Fiery ZX motherboard has four DIMM sockets (J44-J47) which are configured in two banks (banks 0 and 1). Bank 0 consists of DIMM sockets J44 and J45; bank 1 consists DIMM sockets J46 and J47. Currently the Fiery ZX is configured for 160MB or 256MB. For 160MB configurations, two 64MB DIMMs are installed in bank 0 and two 16MB DIMMs are installed in bank 1. For 256MB configurations, two 128MB DIMMs are installed in bank 0.

When replacing or upgrading memory, fill bank 0 first and then bank 1. Within a bank each socket must contain the same capacity DIMM. For example, if you install a 128MB DIMM in socket J44, J45 must also contain a 128MB DIMM. Approved DIMMs are available from your service representative.

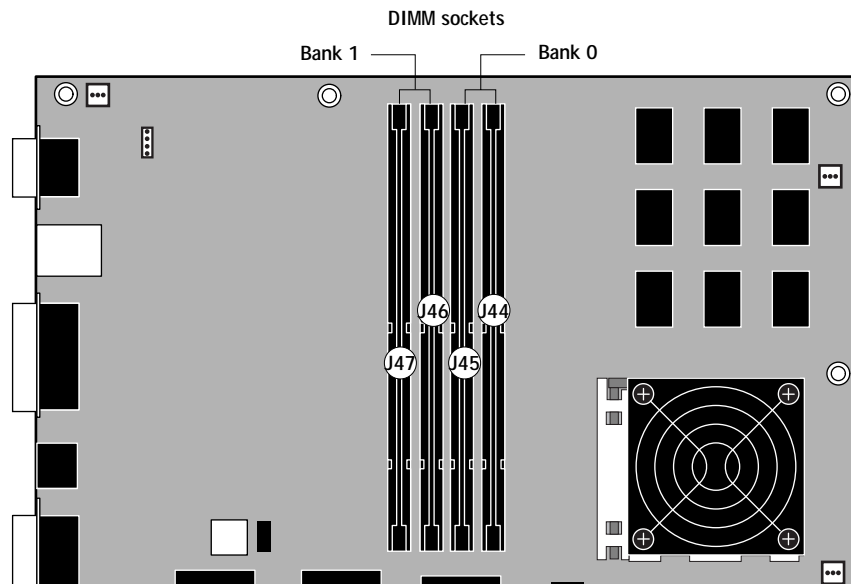

FIGURE 4-21 Motherboard DIMM sockets

4 Service Procedures

TO REPLACE A DIMM

1. To release a DIMM, push outward on the levers on each side of the DIMM. (See Figure 4-22.)

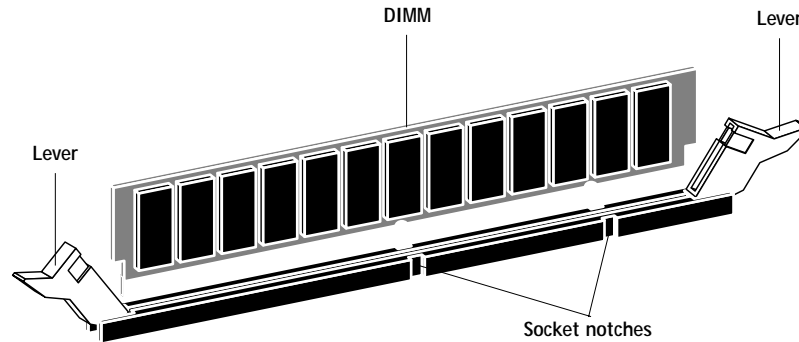

FIGURE 4-22 Releasing a DIMM

2. Slide the DIMM straight out of the socket.
3. To replace a DIMM, slide it straight into the socket and close the levers on each side to lock it into place.

Make sure that the levers close securely around the ends of the DIMM and that each DIMM is fully seated in its socket.

NOTE: DIMMs fit the socket only one way. The two notches on the bottom of each DIMM should line up with the notches in the socket.

4. See "Restoring Fiery ZX functionality after service" on page 4-11.

4

Motherboard

Motherboard battery

The battery on the motherboard is located at BT1. The battery provides support for the realtime clock chip on the motherboard.

NOTE: Leaving the copier powered on and connected to the Fiery ZX while the Fiery ZX is powered off can lead to excessive drain on the Fiery ZX motherboard battery.

TO REPLACE THE MOTHERBOARD BATTERY

1. Locate the battery on the motherboard (see Figure 4-18 on page 4-23, key location 15).
2. Carefully lift up the clip that holds the battery.

Use caution when lifting up the clip; excessive force could cause the clip to lose its tension.

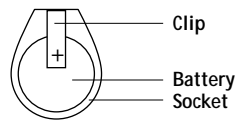

FIGURE 4-23 Motherboard battery

3. Pull the battery out of its socket and release the clip.
4. To insert a new battery, slide the battery into the socket under the clip with the positive (+) side facing up.

Make sure the clip holds the battery securely in the socket.

5. See "Restoring Fiery ZX functionality after service" on page 4-11.

NOTE: When you power on the Fiery ZX, let the startup diagnostics complete, then power off and on again to reinitialize the realtime clock.

4 Service Procedures

Motherboard jumpers

The following section describes the locations and settings for the four jumper blocks on the motherboard.

NOTE: The jumper area in the table below shows the current shipping configuration.

Jumper	Jumper area (shipping configuration)	Description
J30		<ul style="list-style-type: none"> • SP3-SP0 CPU speed. The setting must correspond to the CPU installed on the motherboard. In the default configuration jumpers on SP2-SP0 configure the bank for 533MHz. • CF0 For factory diagnostics. No jumper is installed. • CF1-CF2 Cache size. Jumper installed on CF1 configures 1Mbyte cache. All other jumper configurations are reserved for future use. • CF4 For factory diagnostics. No jumper is installed. • CF5-CF7 For factory use only. No jumper installed in the default configuration.
J31		<ul style="list-style-type: none"> • Flash enable Allows the flash on the motherboard to be updated. Jumper is installed on pins 2 and 3 to enable flash updates.
J52		<ul style="list-style-type: none"> • Allows programming of the Altera chip. No jumpers are installed.
J22		<ul style="list-style-type: none"> • A jumper must be installed on pins 2 and 3.

4 Motherboard

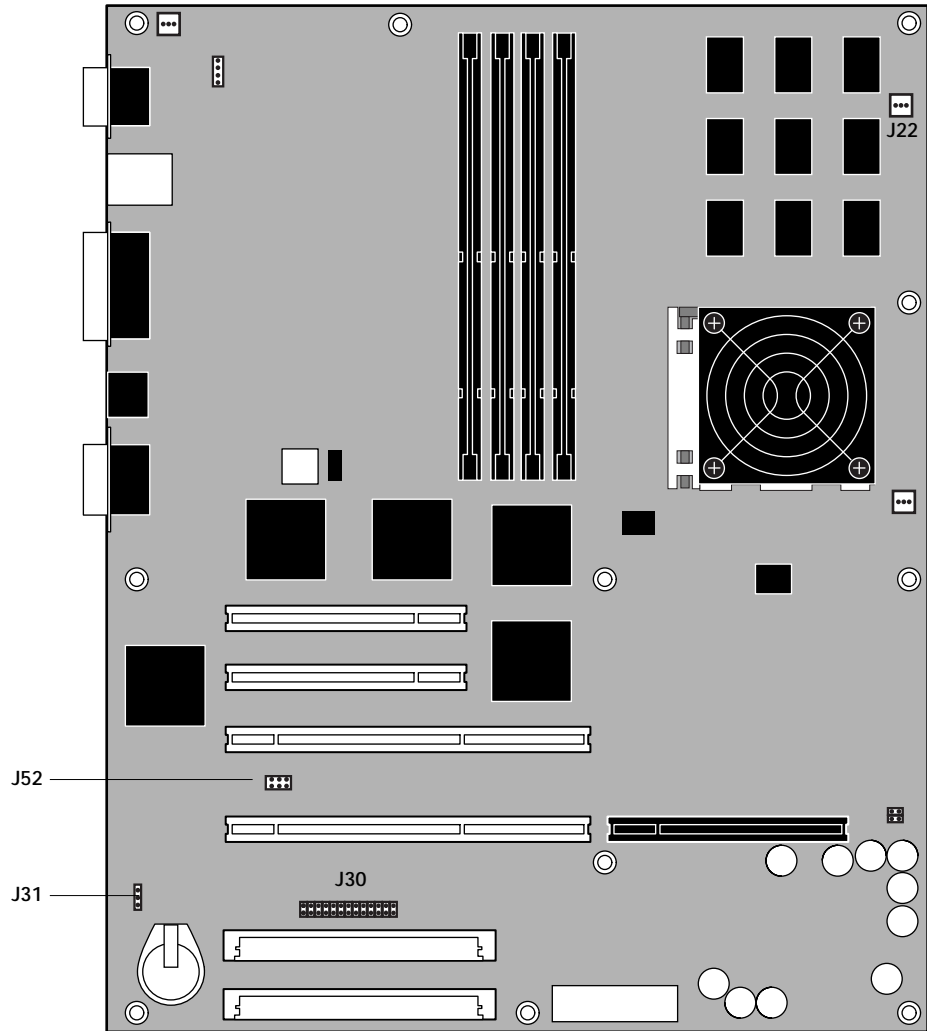

FIGURE 4-24 Motherboard jumper locations

4 Service Procedures

HDD backplane board

The HDD backplane board is installed above the CD-ROM drive and provides the connection for the HDD. It also provides connections for the user interface board and the motherboard.

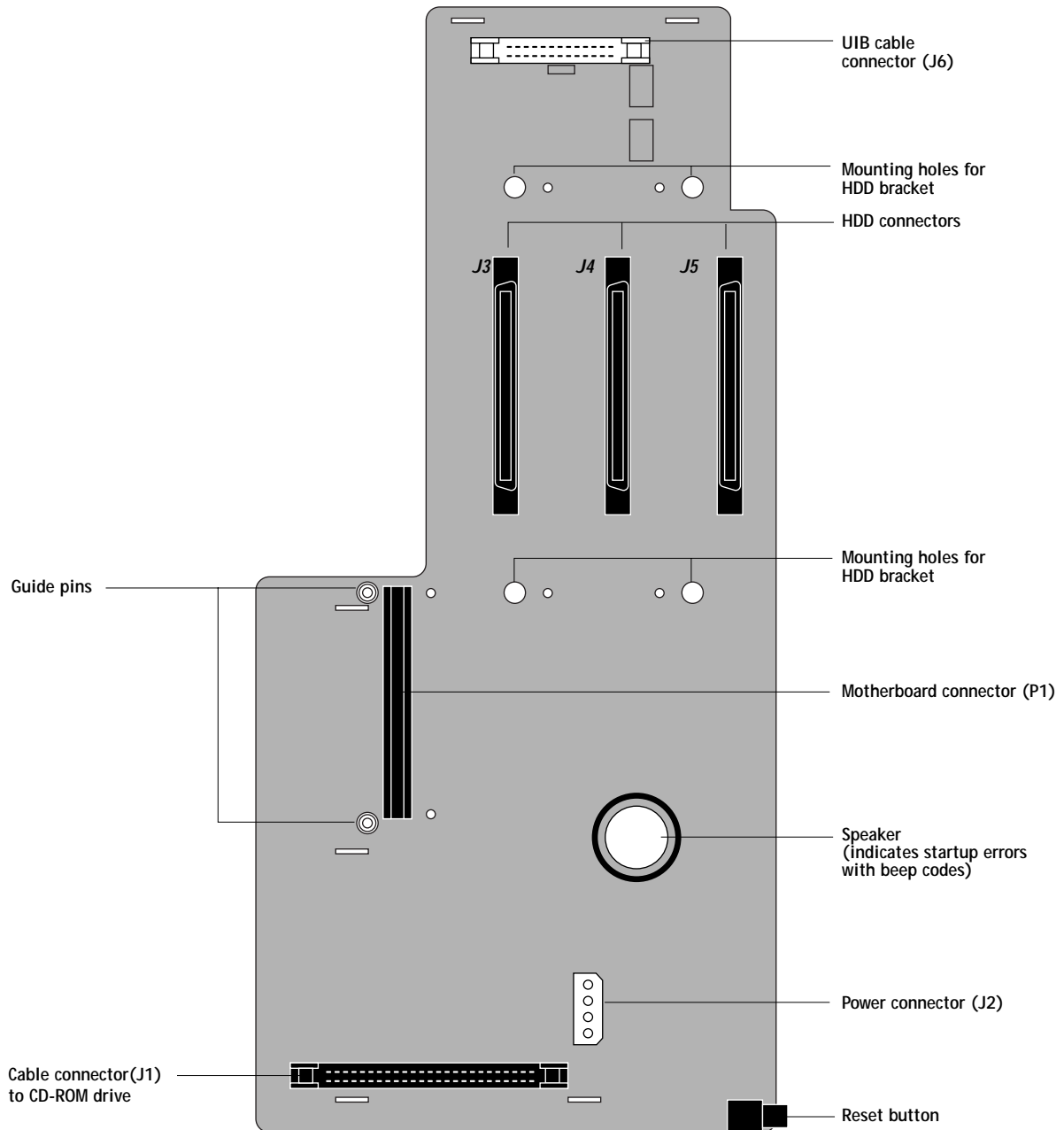

FIGURE 4-25 HDD backplane board

4

Motherboard

TO REMOVE THE HDD BACKPLANE BOARD

1. Shut down and open the Fiery ZX as described in "To shut down the Fiery ZX" on page 4-3 and "To open the Fiery ZX" on page 4-3.
2. Remove the HDD and the HDD bracket (see "To remove the HDD" on page 4-41 and "To remove the HDD bracket" on page 4-43).

The four screws that secure the HDD bracket also secure the HDD backplane board to the tray.

You will remove the front panel and disconnect the UIB cable from the HDD backplane board when you remove the HDD bracket.

3. Remove the motherboard (see "Removing the Fiery ZX motherboard" on page 4-24).
4. Disconnect the SCSI cable that attaches to the HDD backplane board at connector J1.
5. Disconnect the power supply cable that attaches to the HDD backplane board at connector J2.

6. Gently lift the board out of the tray and place the board in an antistatic bag.

If the plastic standoffs around the mounting holes at the base of the tray come loose, be sure to set them aside so they can be replaced later (not included in later models).

TO REPLACE THE HDD BACKPLANE BOARD

1. Make sure the plastic standoffs are in place around the mounting holes at the base of the Fiery ZX tray (plastic standoffs are not included in later models).
2. Angle the HDD backplane board into the tray so that the reset switch fits through the slot cutout in the front of the cover.

Also align the board with the mounting holes in the base of the tray.

3. Connect the large 4-pin power supply cable to the HDD backplane board at J2.
4. Connect the SCSI cable from the CD-ROM drive to connector J1 on the HDD backplane board.
5. Replace the motherboard as described in "To replace the motherboard" on page 4-27.
6. Replace the HDD bracket and HDD (see "To replace the HDD bracket" on page 4-44 and "To replace the HDD" on page 4-42).

The four screws that secure the HDD bracket also secure the HDD backplane board to the tray.

The front panel and the UIB cable are replaced when you replace the HDD bracket.

7. See "Restoring Fiery ZX functionality after service" on page 4-11.

4

Service Procedures

Fans

A fan on the back panel of the Fiery ZX, and a fan on the motherboard CPU run continuously when the system is on. You should hear the fans start as soon as you power on the Fiery ZX. If you don't hear the fans or a fan error message is displayed on the Control Panel, the most likely problem is a faulty power connection (see "To check board and cable connections" on page 4-8).

Back panel fan

The following steps describe the procedure required in order to replace the fan installed on the back panel of the Fiery ZX.

TO REMOVE THE BACK PANEL FAN

1. Shut down and open the Fiery ZX, as described in "To shut down the Fiery ZX" on page 4-3 and "To open the Fiery ZX" on page 4-3.
2. Unplug the 3-pin fan connector from motherboard connector J2.
3. Pull on one edge of the fan to release it from the mounting bracket.

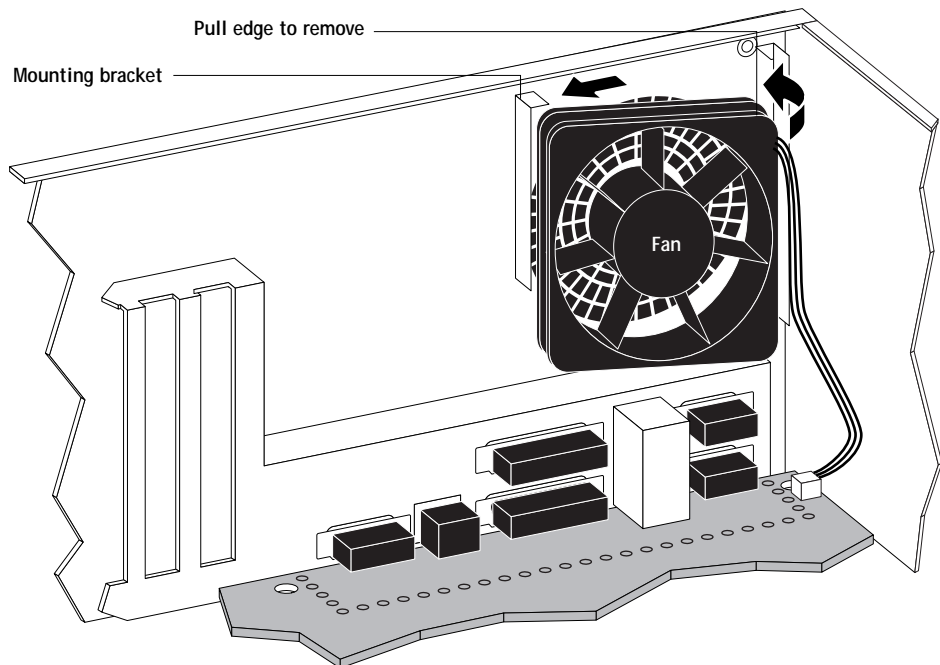

FIGURE 4-26 Removing the fan

4. Remove the fan from the tray.

4

Power supply

TO REPLACE THE BACK PANEL FAN

1. Angle one edge of the fan into the mounting bracket on the back panel of the Fiery ZX and snap the fan into the clips on the bracket (see Figure 4-26 on page 4-36).
An arrow on the side of the fan indicates the airflow direction. Make sure the fan is positioned so that the arrow is at the top of the tray and points out toward the back panel.
2. Plug the 3-pin fan connector into motherboard connector J2. See Figure 4-18 on page 4-23.
3. Reassemble the Fiery ZX and verify functionality (see the steps described in “Restoring Fiery ZX functionality after service” on page 4-11).
4. Check the fan vent on the Fiery ZX back panel to make sure air is coming out the back. If the air is not coming out the back, the fan is installed incorrectly.

CPU fan

The following steps describe the procedure required in order to replace the fan installed on the CPU.

TO REMOVE THE CPU FAN

1. Remove the CPU fan cable from connector J21 on the motherboard.
 2. Remove the four screws on top of the CPU and remove the fan.
Four spacers are installed between the heatsink and the fan. Make sure you set them aside so they can be replaced later.
-

TO REPLACE THE CPU FAN

1. Align the four spacers on top of the mounting holes on the CPU heatsink.
2. Carefully place the fan over the spacers and insert the screws through the spacers.
An arrow on the side of the CPU fan indicates the airflow direction. Make sure the CPU fan is positioned so that the arrow is pointing down in the direction of the CPU.
3. Tighten the four screws that secure the fan to the heatsink.
4. Connect the CPU fan cable to connector J21 on the motherboard.

Power supply

The fan-cooled 239 watt power supply used in the Fiery ZX has an automatic input voltage selection circuit. The input voltages are 90-135VAC and 180-265VAC.

4 Service Procedures





Checking voltages

You can check power supply functionality using a voltmeter at the following locations:

- Connector that supplies power to the motherboard
- Connector that supplies power to the HDD backplane board
- Connector that supplies power to the CD-ROM drive
- Connector for future options

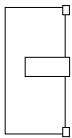
Test voltages on the cable connectors on the power supply, not on the board connectors. Table 4-1 describes the Fiery ZX power connectors.

TABLE 4-1 Fiery ZX power connector

Connector	Pins	Voltage
 20-pin Motherboard	1, 2, 11	3.3V
	3, 5, 7, 13, 15, 16, 17	common
	18	-5V (not connected)
	4, 6, 19, 20	+5V
	10	+12V
	12	-12V
	14	Power on
	8	Supply Power ok
	9	not connected
	 Large 4-pin HDD backplane board	1
2		common
3		common
4		+5V
 Large 4-pin CD-ROM drive	1	+12V
	2	common
	3	common
	4	+5V
 Small 4-pin for future options	1	+12V
	2	common
	3	common
	4	+5V

4

Power supply

Removing and replacing the power supply

This section describes how to remove and replace the power supply and all cables.

TO REMOVE THE POWER SUPPLY

1. Shut down and open the Fiery ZX as described in "To shut down the Fiery ZX" on page 4-3 and "To open the Fiery ZX" on page 4-3.
2. Disconnect the 20-pin power cable at connector J3 on the motherboard.
3. Disconnect the large 4-pin power cable at connector J2 on the HDD backplane board (see Figure 4-5 on page 4-9).
4. Cut the tie wraps on the side of the drive bracket that hold the large 4-pin power cable to the HDD backplane board in place.
5. Disconnect the large 4-pin power cable that is connected to the CD-ROM drive.
6. Remove the four screws on the back panel of the Fiery ZX that attach the power supply to the tray.
Set the screws aside so they can be replaced later.
7. Slide the power supply out of the tray.

TO REPLACE THE POWER SUPPLY

1. Set the new power supply inside the bottom left corner of the tray and attach it from the outside with four screws.
2. Connect the 20-pin power cable to the motherboard power connector (J3).
3. Replace the tie wraps that hold the HDD backplane power supply cable on the side of the drive bracket.
The cable is routed through the tie wraps on the drive bracket and connects to the HDD backplane board.
4. Connect the large 4-pin power cable to the HDD backplane board (J2).
5. Connect the large 4-pin power cable to the power connector on the CD-ROM drive.
6. Reassemble the Fiery ZX and verify its functionality (see "Restoring Fiery ZX functionality after service" on page 4-11).
If you cut any tie wraps, make sure you replace them.

4 Service Procedures

Hard disk drive

The factory-installed HDD (hard disk drive) in the Fiery ZX is formatted and loaded with Fiery ZX system software, including the network drivers and Fiery ZX Adobe printer fonts. The HDD is also used to store spooled print jobs. Available space on the HDD is displayed in the Control Panel.

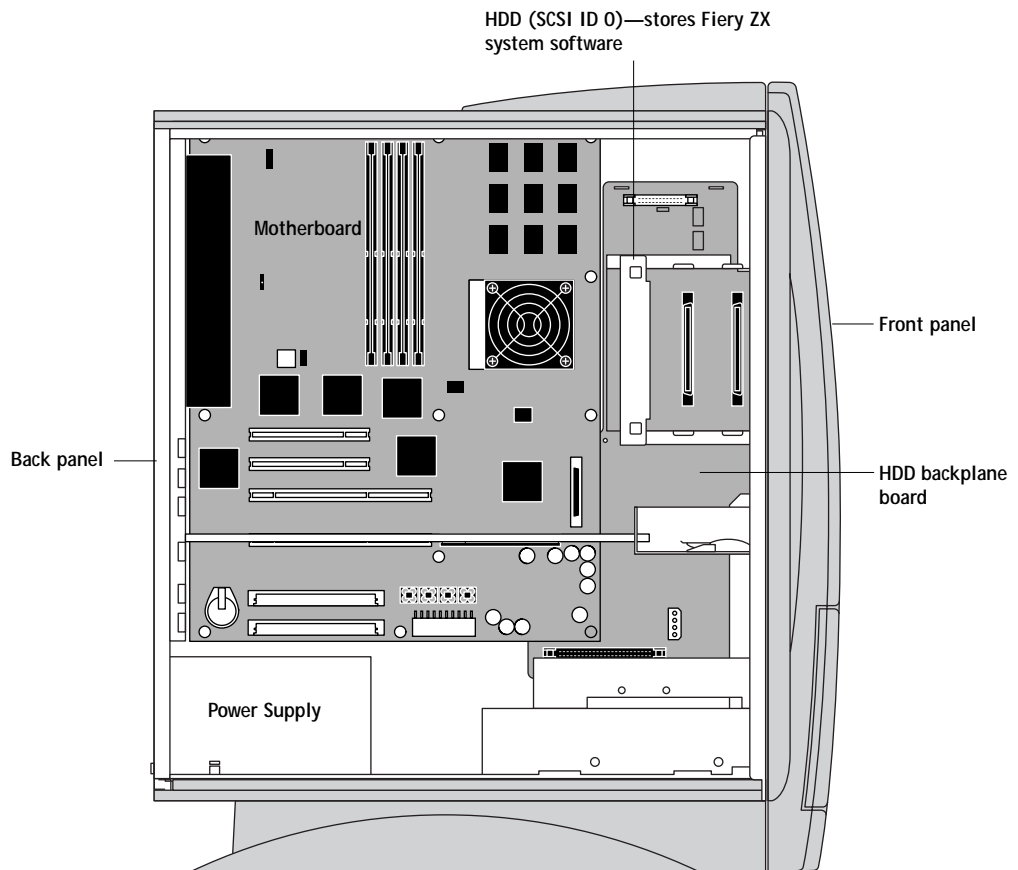

FIGURE 4-27 Fiery ZX HDD (hard disk drive)

The HDD is installed in connector J3 on the HDD backplane board; connectors J4 and J5 are available for future HDD support.

Fiery ZX system software and installation instructions are made available to service technicians for field replacement.

4 Power supply

If you are replacing a Fiery ZX HDD, you will need:

- The appropriate Fiery ZX system software including documentation for the Fiery ZX you are servicing
- Compatible version of the user software for networked computers that will be printing to the Fiery ZX

TO REMOVE THE HDD

1. Shut down and open the Fiery ZX, as described in “To shut down the Fiery ZX” on page 4-3 and “To open the Fiery ZX” on page 4-3.
2. Loosen the two screws on the outside of the HDD bracket (see Figure 4-28).

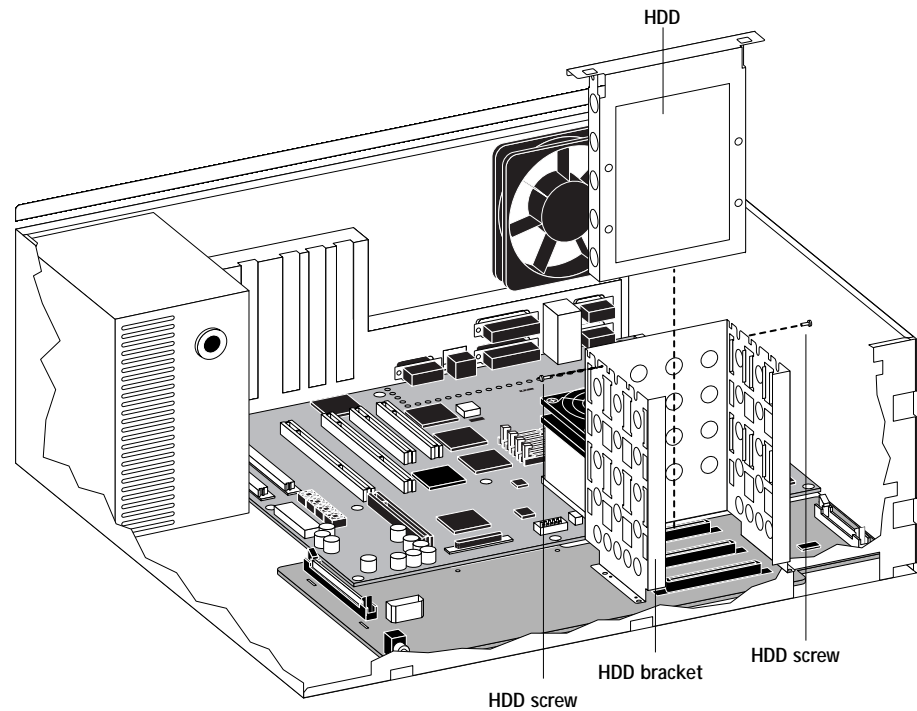

FIGURE 4-28 Removing and replacing the HDD

3. Gently lift out the HDD.



Do not unscrew the six screws on the rounded side of the HDD. Loosening these HDD screws will break the seal and void the HDD warranty.

Do not touch the drive with magnetic objects (such as magnetic screwdrivers) and avoid placing items such as credit cards and employee ID cards that are sensitive to magnets near the HDD.

4. Place the HDD in an antistatic bag.

4

Service Procedures

Replacement hard disk drives are not shipped with any Fiery ZX software pre-installed. After installing the drive, you need to install the appropriate Fiery ZX system software as described in the instructions included with the System Software CD.

TO REPLACE THE HDD

1. If you are installing a new HDD, unpack the drive.
Do not touch the HDD with magnetic objects or place objects sensitive to magnets near the drive.
2. Insert the drive into the slot in the HDD bracket so that it is aligned with connector J3 on the HDD backplane board.
3. Once the HDD is securely installed in the connector on the HDD backplane board, tighten the two screws on the outside of the HDD bracket (see Figure 4-28 on page 4-41).
If the HDD and the HDD bracket screw holes do not line up, the drive may not be correctly aligned in the bracket. Remove the HDD and try again.
4. Reassemble the Fiery ZX (see "Restoring Fiery ZX functionality after service" on page 4-11).
5. Re-establish the connections at the back of the Fiery ZX.
6. If you replaced the HDD with a new drive, install Fiery ZX system software (see "Fiery ZX system software" on page 4-49).
If a startup error appears on the Control Panel when you turn on the Fiery ZX, check the Fiery ZX connections. If a startup error still appears, call your authorized service/support center.

4 Power supply

TO REMOVE THE HDD BRACKET

1. Shut down and open the Fiery ZX, as described in “To shut down the Fiery ZX” on page 4-3 and “To open the Fiery ZX” on page 4-3.
2. Remove the front panel so you can access the two HDD bracket screws on the front (see “To remove the front panel” on page 4-6).

Make sure the UIB cable is disconnected from J6 on the HDD backplane board.

3. Remove the two HDD bracket screws on the front of the cover.

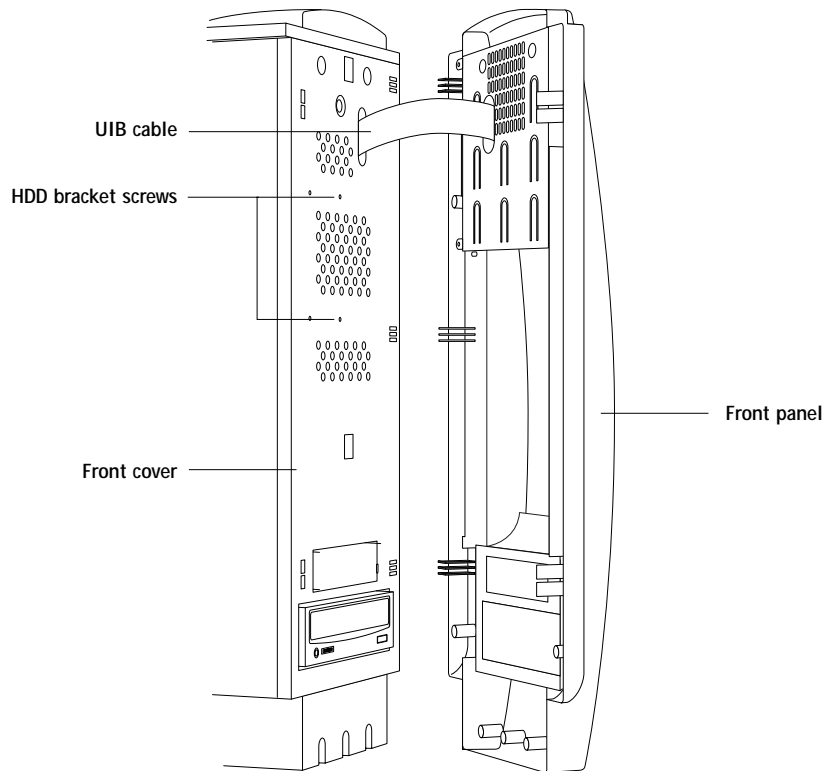

FIGURE 4-29 Removing HDD bracket screws from the front cover

4. Remove the HDD installed in the bracket (see “To remove the HDD” on page 4-41).

4 Service Procedures

5. Remove the four screws that attach the bracket to the HDD backplane board.

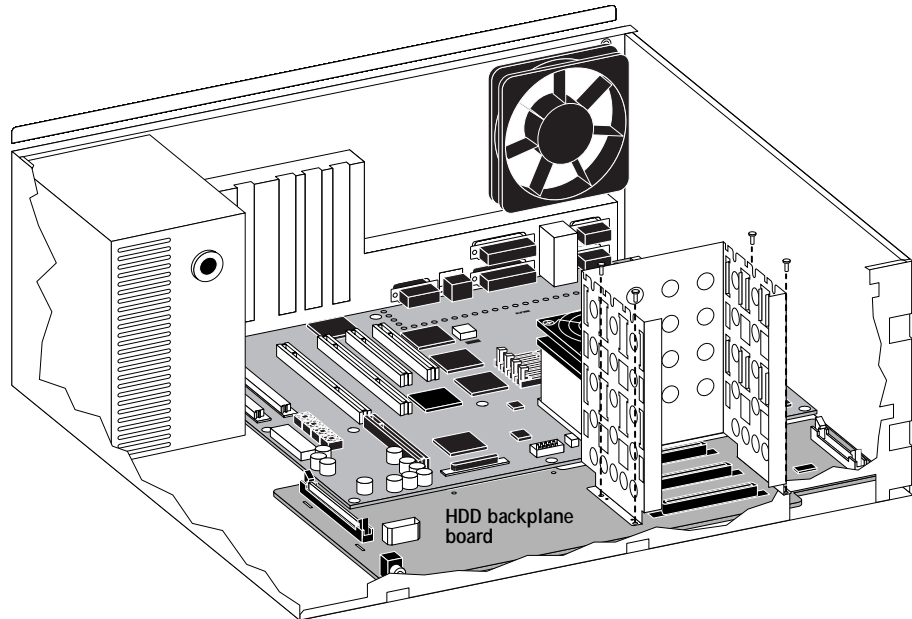

FIGURE 4-30 Removing the HDD backplane screws

TO REPLACE THE HDD BRACKET

1. Place the bracket on top of the HDD backplane board so that the mounting holes in the bracket line up with the holes in the HDD backplane board.
2. Insert the four screws that secure the bracket to the HDD backplane board and the tray.
3. With the front panel removed, replace the two HDD bracket screws in the front of the cover (see Figure 4-29 on page 4-43).
4. Replace the front panel (see "To replace the front panel" on page 4-7).
5. Replace the HDD (see "To replace the HDD" on page 4-42).
6. See "Restoring Fiery ZX functionality after service" on page 4-11.

4

Power supply

CD-ROM drive

The CD-ROM drive is located behind the drive door at the bottom of the front panel. It is used to install Fiery ZX system software.

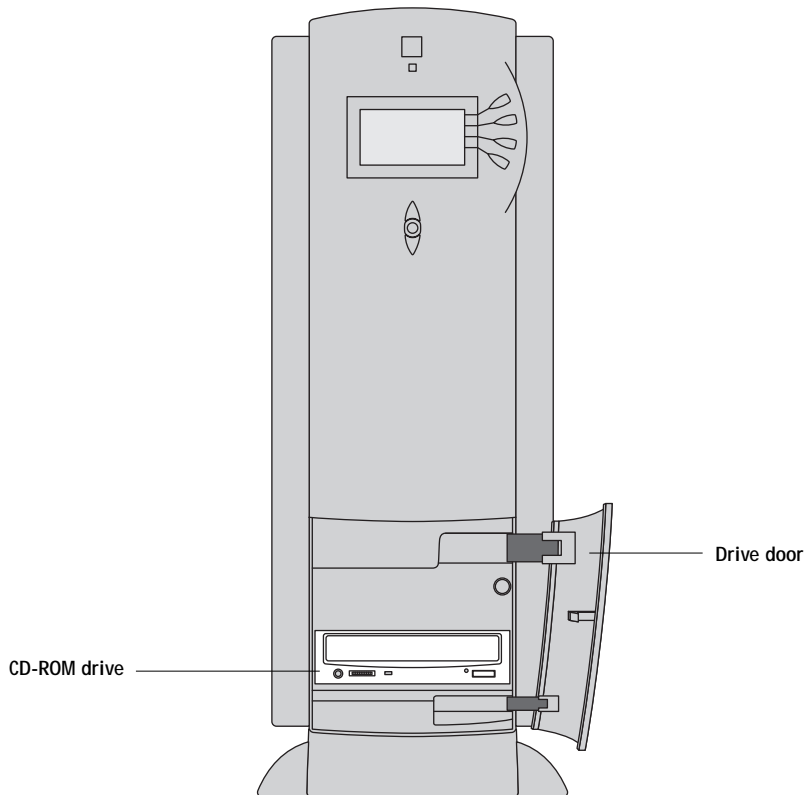

FIGURE 4-31 CD-ROM drive location

TO REMOVE THE CD-ROM DRIVE

1. Shut down and open the Fiery ZX, as described in "To shut down the Fiery ZX" on page 4-3 and "To open the Fiery ZX" on page 4-3.
2. Remove any cables connected to the back of the CD-ROM drive.
In order to remove the CD-ROM drive you need to remove the bracket that encloses it.
3. Cut the tie wraps that hold the power supply cable on the side of the drive bracket.
4. Remove the screw on the back edge of the drive bracket. This screw secures the bracket to the tray.
5. Pull the bracket with the CD-ROM drive installed out of the tray. Be careful not to damage any components when removing the bracket.

4

Service Procedures

6. Remove the four screws that secure the CD-ROM drive to the bracket and slide the drive out of the bracket.

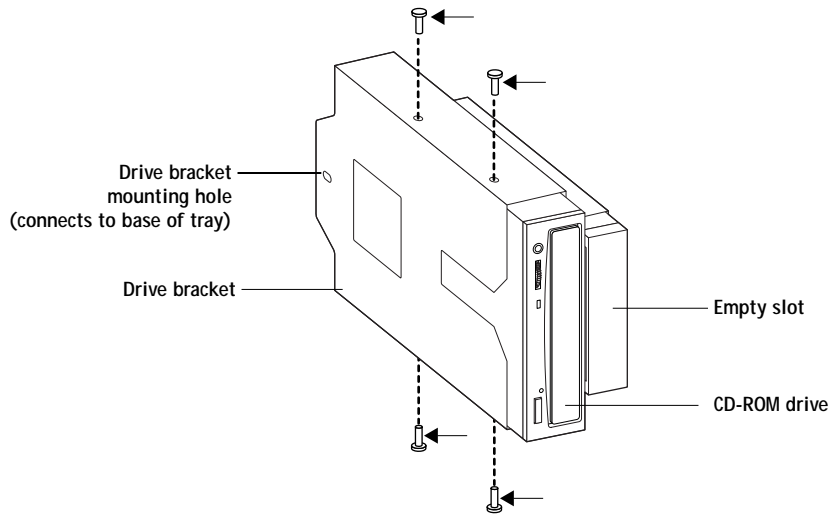

FIGURE 4-32 CD-ROM drive bracket

TO REPLACE THE CD-ROM DRIVE

1. With the drive bracket removed, slide the replacement CD-ROM drive into the bracket in the bottom slot.
2. Attach the four screws that secure the CD-ROM drive to the bracket (see Figure 4-32).
3. Slide the bracket into the tray and push it forward until the drive fits securely into front cover cutout.
4. Replace the screw that secures the bracket to the base of the tray.
5. Replace the tie wraps that hold the power supply cable on the side of the drive bracket. The power supply cable is routed through the tie wraps on the drive bracket and connects to the HDD backplane board.
6. Re-establish cable connections to the back of the CD-ROM drive and reassemble the Fiery ZX ("Restoring Fiery ZX functionality after service" on page 4-11).

4 Power supply

Front panel components

The front panel holds jewels, the user interface board, and buttons. This section describes replacing jewels and buttons on the front panel. For information on replacing the user interface board, see “User interface board” on page 4-20.

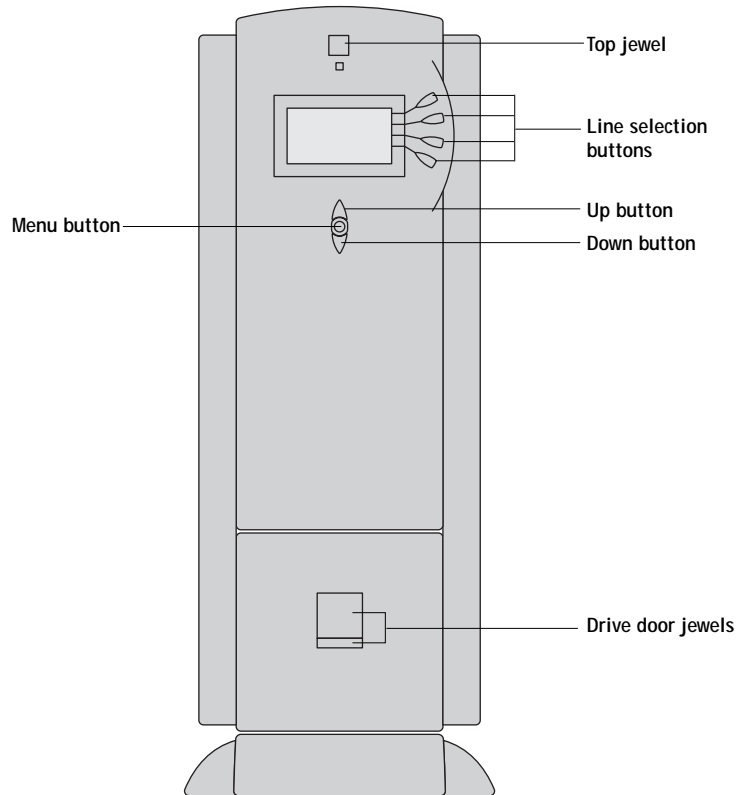

FIGURE 4-33 Front panel jewels and buttons

4

Service Procedures

Jewels

Some upgrades or product modifications may require you to replace a jewel on the front panel of the Fiery ZX. The following procedure describes how to replace a jewel.

TO REPLACE FRONT PANEL JEWELS

1. If you are replacing the top jewel, remove the front panel as described in "To remove the front panel" on page 4-6. To replace the jewels on the drive door, open the drive door.
Now you have access to the tabs on the back side of the jewel.
2. Remove the jewel from the front panel.
Squeeze the tabs on the back side of the jewel while pushing it out of its slot.
3. Insert the new jewel into the empty slot.
Push the jewel into the slot from the front panel until it snaps into place.
4. If necessary, reassemble the Fiery ZX (see "Restoring Fiery ZX functionality after service" on page 4-11).

Buttons

The Control Panel buttons are located in cutouts in the front panel and are designed to fit only one way. In position the buttons make contact with the button pads on the front of the user interface board and provide users with manual status/control capability from the Control Panel.

TO REPLACE FRONT PANEL BUTTONS

1. Remove the front panel (see "To remove the front panel" on page 4-6).
2. Remove the user interface board (see "To remove the user interface board" on page 4-21).
3. Place the front panel buttons in the appropriate cutouts; notice the buttons fit only one way in the cutouts.
4. Reassemble the Fiery ZX (see "Restoring Fiery ZX functionality after service" on page 4-11).

4

Fiery ZX system software

Fiery ZX system software

The Fiery ZX system software kit enables you to install the Fiery ZX system software on the HDD.

Use this kit when:

- You replace the Fiery ZX HDD with a new or optional HDD
- You replace the motherboard
- You upgrade to a more current version of the system software

Installing system software deletes the list of jobs in the Job Log and any jobs in the queues. The customer can save a current list of jobs (not the actual job) from the Job Log using Fiery Spooler.

Also, installing system software deletes all fonts installed on the Fiery ZX. Resident fonts will be restored during system software installation, however any additional fonts that the customer may have downloaded will need to be reinstalled after system software installation. To determine if any additional fonts were downloaded to the Fiery ZX, print the Font List before beginning the following procedure and again after installing system software. Any fonts not listed after installation will need to be reinstalled using Fiery Downloader. See the *Printing Guide* for more information.

TO INSTALL FIERY ZX SYSTEM SOFTWARE

1. If you have not done so already, print the Configuration page from the Functions menu (if possible) to record the customer's Setup Configuration.
Setup settings are reset to the default configuration when system software is installed.
2. Print the Font List from the Functions menu.
The Font List details what fonts are resident on the Fiery ZX HDD. Along with the fonts provided on the System Software CD, the customer may have installed additional fonts that will be deleted when system software is installed.
3. Press the eject button on the CD-ROM drive and insert the System Software CD.
4. Restart the Fiery ZX using Reboot Server from the Functions menu.

4

Service Procedures

5. While the Fiery ZX is running the startup diagnostics, hold down the fourth line selection button on the Control Panel to access the Installation & Info screen.

NOTE: Do not press the second line selection button during the startup diagnostics. Doing so accesses screens that are for factory use only and may cause undesirable results that may require you to return the system to Electronics for Imaging, Inc. for repair.

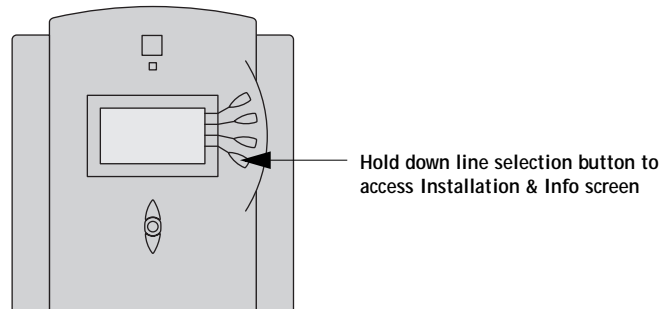

If you do not press the fourth line selection button before the end of the diagnostics, the Fiery ZX continues the startup process and you must restart the system and try again.

The following screen is displayed.

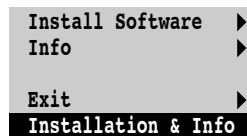

6. Select Install Software.
Messages are displayed on the Control Panel as the HDD is reformatted, the flash ROM is updated, and the installation files are copied to the HDD.
If the installation is successful, the screen indicates that the installation is done.
7. Remove the System Software CD and press any button on the Control Panel to reboot.
The Fiery ZX runs through its startup diagnostics.
8. When the Select Language screen is displayed, select the language you want to appear in the Control Panel.
To select a language different from the one initially highlighted on the Control Panel, use the up and down buttons to scroll through the list and select OK when the desired language is highlighted. After the Fiery ZX reboots, the language you selected appears in the Control Panel.
9. At the Setup screen, configure the customer's settings from the Configuration page you printed earlier.

5

The troubleshooting process

Chapter 5: Troubleshooting

This chapter identifies the source of common problems that may occur with the Fiery ZX and suggests ways of correcting them.

The troubleshooting process

The troubleshooting process is designed to eliminate the most obvious causes of failure before progressing to more complex solutions. “Where problems occur” on page 5-2, gives an overview of the Fiery ZX system and indicates areas most likely to require troubleshooting.

- Problems with initial installation

If the Fiery ZX fails to complete its initial startup and doesn't reach the Idle (ready to print) screen, the most likely cause is a loose cable or board connection. See “Accessing Fiery ZX internal components” on page 4-3 for instructions on opening the Fiery ZX, and “Checking Fiery ZX internal connections” on page 4-8 for descriptions of Fiery ZX parts and connections.

If a loose part or cable is not the cause of the problem, see “Checking the Fiery ZX as a stand-alone unit” on page 5-8, and “Checking the entire Fiery ZX system” on page 5-18.

- Try a phone check before you go to the customer site

“Before you go to the customer site” on page 5-3 suggests areas you should check out before making a call to the customer site. With a phone call you can find out if the problem is a simple operating failure or a failure caused by a network or configuration change. You can ask the customer to check for loose cables on the back of the Fiery ZX and loose connections at a power strip or outlet.

- Check for obvious causes of problems

“Preliminary on-site checkout” on page 5-4 takes you through the initial visual checkout you should make when you arrive at the customer site. You should check the Fiery ZX internally and externally for the most common problems such as loose cables, connectors, and boards.

- Check the Fiery ZX as a stand-alone unit

“Checking the Fiery ZX as a stand-alone unit” on page 5-8 describes the checks you should perform on the Fiery ZX if the initial checks fail to identify the cause of a problem. With the Fiery ZX disconnected from the copier and the network, test the Fiery ZX as a stand-alone unit.

This section describes possible startup errors and explains how to run and interpret Fiery ZX startup diagnostics.

5 Troubleshooting

- Check the entire Fiery ZX system

“Checking the copier interface” on page 5-18 explains how to print the Test Page from the Fiery ZX. “Checking network connections” on page 5-21 includes guidelines for checking the network connections between the Fiery ZX and the computers or workstations to which it is connected, and also provides information on printing problems.

Where problems occur

The Fiery ZX is a server for color copiers, and it is generally part of a configuration like the one shown below and in Figure 5-2 on page 5-3. Problems may occur in one of three areas:

- Inside the Fiery ZX
- In the interface between the Fiery ZX and the color copier
- In the interface between the Fiery ZX and the workstations or computers to which it is connected

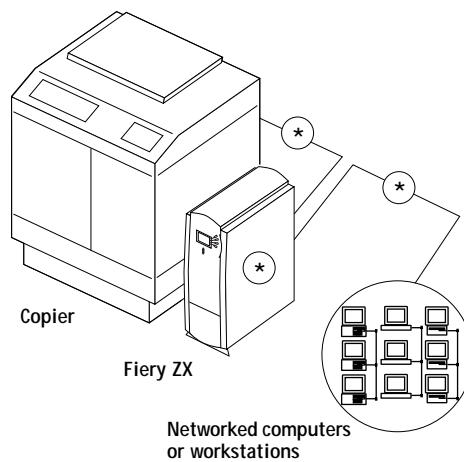

FIGURE 5-1 Troubleshooting the system

This chapter does not attempt to provide troubleshooting information for attached computers such as PC-compatibles or Mac OS computers, for color copiers, or for extensive networks. You should refer problems in these areas to the appropriate service departments and network administrators.

5

Before you go to the customer site

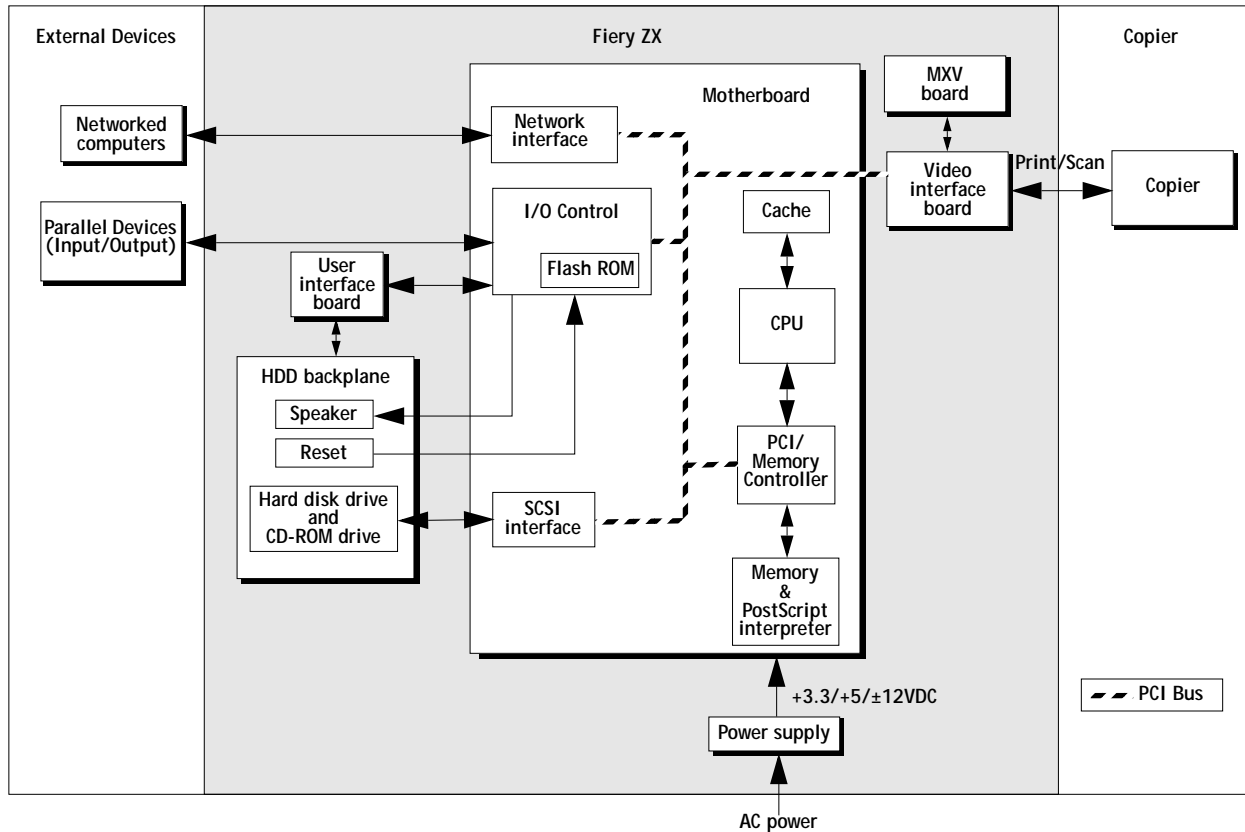

FIGURE 5-2 Functional diagram of a typical configuration

Before you go to the customer site

Before you make a service call to a customer site, talk to the customer on the phone and check out the following items:

1. Does the copier work when it is not connected to the Fiery ZX?

If the copier works but the user cannot print a Fiery ZX Test Page, have the customer check the Control Panel on the Fiery ZX for an error message.

If the Fiery ZX Control Panel reports an error, the customer can check the copier interface cable connection between the Fiery ZX and the copier.

2. Is the failure caused by a simple operating problem?

- Is there a printing problem?
 - Does the Fiery ZX Test Page fail to print?
 - Does the Fiery ZX fail to respond to a print command?
 - Does printing seem to take a long time?

5 Troubleshooting

- Is print quality poor?
- Does the Fiery ZX fail to appear in the list of printers?
- Has the customer noted any error messages on the Fiery ZX or the copier screen?

If the answer to any of these questions is yes, refer the customer to a list of Fiery ZX error messages in the *Printing Guide*.

If the customer has followed the corrective actions in the *Printing Guide* and still fails to solve the problem, be prepared to make a service call. Keep a log of the failures and messages the customer has observed.

3. Has the customer made any network changes?

If so, request that the customer's network administrator verify the Fiery ZX network requirements. See "Checking network connections" on page 5-21.

4. Has the customer added or removed any equipment that might impact the operation of the Fiery ZX?

If so, obtain a list of the modifications. This should direct you toward possible problem areas. For example, if the HDD has been replaced, system software may need to be re-installed.

5. Is the user having printing problems with a particular image file?

If there are problems with files from particular applications, the user may be more successful using different print settings. The *Color Guide* provides print settings for some popular applications.

If your preliminary phone call fails to clear up the problem, proceed to the second phase, the preliminary on-site checkout.

Preliminary on-site checkout

Your goal in the preliminary on-site checkout is to eliminate obvious problems such as loose or missing cables and connectors, or loosely seated printed circuit boards.

5

Preliminary on-site checkout

Checking the interface cables

Before you remove the side and front panel of the Fiery ZX to check internal components make sure that:

- All interface cables to the system are plugged into the proper connectors on the back panel of the Fiery ZX (see Figure 5-3).
- The power cable is plugged into the wall supply.
- The power switch on the back panel of the Fiery ZX is powered on.

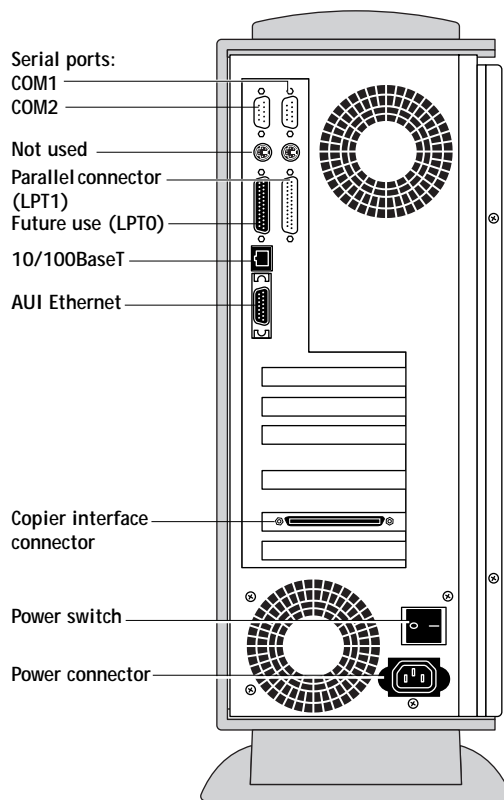

FIGURE 5-3 Back panel of Fiery ZX

If all the connectors are properly in place and the power is on, proceed to the next stage of troubleshooting.

5 Troubleshooting

Checking the internal components

To check the internal components you must remove the side and front panel of the Fiery ZX.



Before you remove the side and front panels of the Fiery ZX, be aware of the safety precautions you should take when handling the Fiery ZX, and use ESD precautions when handling printed circuit boards and electronic components. To review the safety precautions, see “Precautions” on page -xiii.

Use the guidelines in Chapter 4 when disassembling, checking, and reassembling the Fiery ZX.

TO CHECK INTERNAL COMPONENTS

1. Shut down the Fiery ZX (see “To shut down the Fiery ZX” on page 4-3).
2. Remove the side panel and the front panel as described in “To open the Fiery ZX” on page 4-3 and “To remove the front panel” on page 4-6.
3. Before you touch any components inside the Fiery ZX, attach a grounding strap to your wrist and discharge any static electricity on your body by touching the metal cover of the Fiery ZX.
4. Inspect the inside of the Fiery ZX. For details, see “Checking Fiery ZX internal connections” on page 4-8.

Make sure no foreign materials have been dropped into the tray. Figure 5-4 on page 5-7 shows an exploded view of the system components.

- Look for obviously loose boards and reseat each board securely in its connector on the motherboard.
 - Look for cables that are obviously loose. Reseat each connector firmly.
 - Make sure each connector is properly aligned with its mating connector. If the pins are offset from each other, the board affected will not function properly. Especially check the connection between the motherboard and the HDD backplane board.
5. Reassemble the Fiery ZX and verify functionality (see “Restoring Fiery ZX functionality after service” on page 4-11).

5

Preliminary on-site checkout

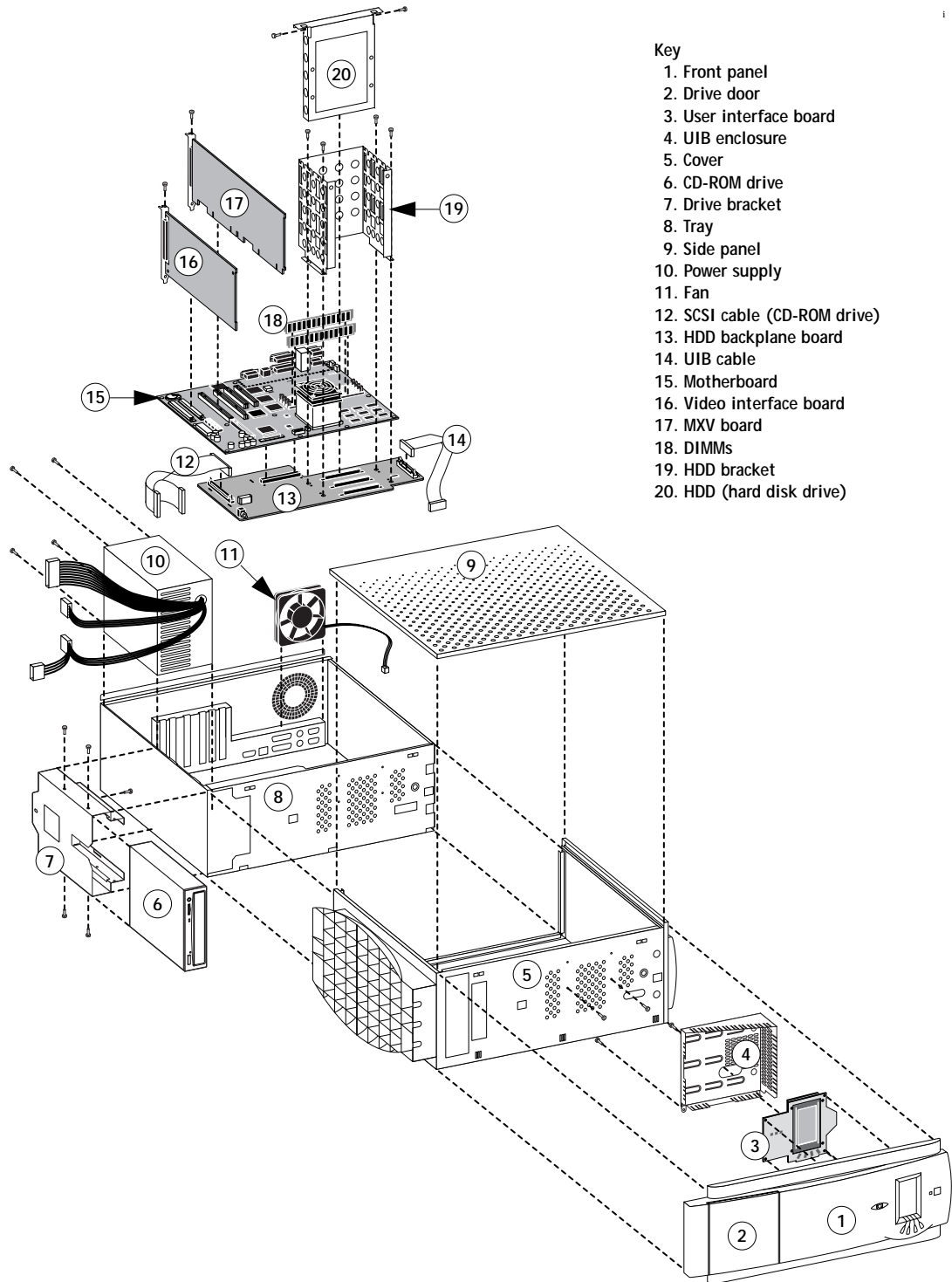

FIGURE 5-4 Exploded view of Fiery ZX components

5 Troubleshooting

Checking the Fiery ZX as a stand-alone unit

To test the Fiery ZX as a stand-alone unit:

- Disconnect the Fiery ZX from the copier and from the network.
- Check for possible startup problems.
- Check Setup (See the *Configuration Guide* for details).

Isolating the Fiery ZX

1. Isolate the Fiery ZX from the copier and from the network by disconnecting the following cables from their connectors on the back panel of the Fiery ZX:
 - Network connector
 - Copier interface connector
 - Parallel port connector (if used)
2. Make sure the power connector to the Fiery ZX is still in place.
3. Power on the Fiery ZX and allow the startup diagnostics to run.

5

Checking the Fiery ZX as a stand-alone unit

Errors and beep codes during startup diagnostics

When you turn on the Fiery ZX or reboot, the system performs diagnostic tests that check the motherboard. While the diagnostic tests are running, the name of each test group is displayed on the Control Panel along with the following information:

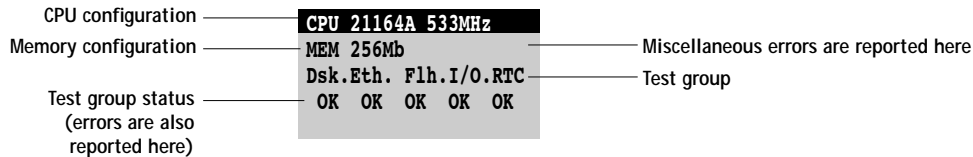

FIGURE 5-5 Startup diagnostic screen

If an error occurs during the startup diagnostics, the red activity light on the Fiery ZX Control Panel turns on. At the end of the diagnostics, the red activity light remains on and the error number appears in the startup diagnostic screen.

Pressing and holding the fourth line selection button at the startup diagnostic screen displays the Installation & Info screen. This screen allows you to reinstall system software if required. You can also view system configuration information from the Info screen.

If the system cannot display the startup diagnostic screen, the Fiery ZX will indicate an error with beep codes and a flashing or solid red activity light.

NOTE: During startup, the diagnostics check the activity light to make sure it is functional. The activity light on the Fiery ZX Control Panel flashes red briefly during this time even though no errors have occurred.

When you encounter any of these conditions, power off the Fiery ZX and inspect the inside of the tray for an obviously loose part or wire. Then check the other components as suggested in the following tables. For all service, see “Accessing Fiery ZX internal components” on page 4-3. When you are finished, see “Restoring Fiery ZX functionality after service” on page 4-11.

Table 5-1 lists the possible beep codes, the area on the motherboard reporting the error, and what the error means. Table 5-2 lists the diagnostic test groups that are run at startup with the corresponding error numbers for a failed test, the area of the Fiery ZX being tested, and the suggested corrective action for the failing test.

5 Troubleshooting

TABLE 5-1 Fiery ZX beep code

Beep code	Area reporting the error	Suggested action
1 beep–pause–2 beeps–pause–3 beeps	U33—Flash ROM	<ul style="list-style-type: none"> • Replace the motherboard.
2 beeps–pause–1 beep	J44—DIMM	<ul style="list-style-type: none"> • Check the DIMM configuration. Make sure that each socket within the bank contains the same DIMM capacity. (Bank 0 consists of sockets J44 and J45; bank 1 consists of J46 and J47.) For example, if you install a 128MB DIMM in socket J44, J45 must also contain a 128MB DIMM. See “DIMMs” on page 4-29 for more information. • Reseat the DIMM in the socket and restart the Fiery ZX in order to run the startup diagnostics. • If the error persists, replace the DIMM indicated.
2 beeps–pause–2 beeps	J45—DIMM	
2 beeps–pause–3 beeps	J46—DIMM	
2 beeps–pause–4 beeps	J47—DIMM	
2 beeps–pause–5 beeps	J44-J47—DIMMs	<ul style="list-style-type: none"> • Make sure all DIMMs installed on the motherboard are Electronics for Imaging, Inc. approved. • Reseat all DIMMs in their sockets and restart the Fiery ZX in order to run the startup diagnostics. • If the error persists, replace each DIMM one at a time with a good DIMM until you locate the faulty DIMM(s). • If the above does not correct the error, you may need to replace the motherboard.
4 beeps–pause	U21—CPU	<ul style="list-style-type: none"> • Replace the motherboard.
6 beeps–pause	U33—Flash ROM	<ul style="list-style-type: none"> • Replace the motherboard.
7 beeps–pause	J44-J47—DIMMs	<ul style="list-style-type: none"> • Check the DIMM configuration. Make sure that each socket within the bank contains the same DIMM capacity. (Bank 0 consists of sockets J44 and J45; bank 1 consists of J46 and J47.) For example, if you install a 128MB DIMM in socket J44, J45 must also contain a 128MB DIMM. See “DIMMs” on page 4-29 for more information. • Make sure all DIMMs installed on the motherboard are Electronics for Imaging, Inc. approved. • If you still have not located the problem, reseat all DIMMs in their sockets and restart the Fiery ZX in order to run the startup diagnostics. • If the error persists, replace each DIMM one at a time with a good DIMM until you locate the faulty DIMM(s). • If the above does not correct the error, you may need to replace the motherboard.
8 beeps–pause	U5-U7, U10-U12, U15-U17—Cache	<ul style="list-style-type: none"> • Replace the motherboard

NOTE: Beep codes continue to loop until the Fiery ZX is shutdown and the error is corrected.

5

Checking the Fiery ZX as a stand-alone unit

TABLE 5-2 Possible errors during startup diagnostics

Test Group	Error number	Area reporting the error	Suggested action	
Miscellaneous (group name is not displayed on the screen)	30	J2—Fan connector on the motherboard	<ul style="list-style-type: none"> • Check the fan cable to make sure it is properly connected and that it is not damaged. • If the cable is damaged, replace the fan on the back panel of the Fiery ZX. • If the error persists, the fan connector on the motherboard may be faulty. Replace the motherboard. 	
	90	J44-J47—DIMMs on motherboard	<ul style="list-style-type: none"> • Reseat all DIMMs in their sockets and restart the Fiery ZX in order to run the startup diagnostics. • If the error persists, replace each DIMM one at a time with a good DIMM until you locate the faulty DIMM(s). • If the above does not correct the error, you may need to replace the motherboard. 	
	91	J44—DIMM	<ul style="list-style-type: none"> • Reseat the DIMM in the socket and restart the Fiery ZX in order to run the startup diagnostics. • If the error persists, replace the DIMM. 	
	92	J45—DIMM		
	93	J46—DIMM		
	94	J47—DIMM		
		H0-H2	U59—PCI-PCI Bridge chip and related logic	<ul style="list-style-type: none"> • Replace the motherboard.
		K0-K2	U78—IX chip and related logic	
Dsk	G0-G2	U67—SCSI chip	<ul style="list-style-type: none"> • Replace the motherboard. 	
	G3	FU1—SCSI fuse	<ul style="list-style-type: none"> • Check HDD connections to the HDD backplane board. • Check the CD-ROM drive SCSI cable connections to the HDD backplane board and the CD-ROM drive. Make sure any devices connected to the SCSI cable are configured correctly. • If the error persists, you may need to replace the motherboard. 	
Eth	I0-I4	U58—Ethernet chip and related logic	<ul style="list-style-type: none"> • Replace the motherboard. 	
	I5	FU2—AUI Ethernet fuse	<ul style="list-style-type: none"> • Remove the Ethernet transceiver connected to the AUI port on the back of the Fiery ZX (see “Ethernet network connections” on page 3-8). • Restart the Fiery ZX in order to run the startup diagnostics. If the startup diagnostics do not report an error with the Ethernet transceiver removed, replace the transceiver. • If the error persists, you may need to replace the motherboard. 	

NOTE: If the customer is not using the AUI port, you can press any key on the Control Panel to bypass the error and continue using the Fiery ZX.

5 Troubleshooting

TABLE 5-2 Possible errors during startup diagnostics (Continued)

Test Group	Error number	Area reporting the error	Suggested action
Flh	80	U33—Flash ROM	<ul style="list-style-type: none"> Reinstall system software (see “Fiery ZX system software” on page 4-49). If the error persists after installing the system software, you may need to replace the motherboard.
	81		
	F1-F4		
I/O	NOTE: This test group is for factory use only. Additional equipment is required in order to perform these tests.		
RTC	E0-E1	BT1—Battery	<ul style="list-style-type: none"> Replace the battery (see “Motherboard battery” on page 4-31). If the error persists after replacing the battery, you may need to replace the motherboard.
	E2	U41—SMC chip	<ul style="list-style-type: none"> Reinstall system software (see “Fiery ZX system software” on page 4-49). If the error persists after installing system software, you may need to replace the motherboard.

5

Checking the Fiery ZX as a stand-alone unit

General Fiery ZX system error conditions

When you startup the Fiery ZX or when you install system software, you may encounter error conditions that are not reported during the startup diagnostics. Table 5-3 lists some of these error conditions and suggests corrective action.

When you first encounter any of these error conditions, power off the Fiery ZX and inspect the inside of the tray for an obviously loose part or cable. Then check other components as suggested below. For service, see “Accessing Fiery ZX internal components” on page 4-3. When you are finished, see “Restoring Fiery ZX functionality after service” on page 4-11.

TABLE 5-3 General Fiery ZX system error conditions

Symptom	Probable cause	Suggested action
No fan sound and Fiery ZX does not start up.	Power connector to the motherboard is faulty or disconnected.	<ul style="list-style-type: none"> • Check power connection to the motherboard.
	Power supply has failed.	<ul style="list-style-type: none"> • Replace the power supply.
Buttons do not work on the Control Panel.	Connection to the user interface board is faulty or the user interface board is faulty.	<ul style="list-style-type: none"> • Check connections to the user interface board. • If the problem persists, replace the user interface board.
Nothing appeared on the Control Panel when the Fiery ZX was turned on or the backlighting on the Control Panel is discolored.	Connections to the user interface board are faulty or the user interface board is faulty.	<ul style="list-style-type: none"> • Check the user interface cable connection on the HDD backplane board and on the user interface board. • If the problem persists, replace the user interface board.
	Power connector to the HDD backplane board is loose or disconnected, or the power supply is faulty.	<ul style="list-style-type: none"> • Check the power connection to the HDD backplane board. • If the problem persists, replace the power supply.
	CPU fan cable is faulty or not connected to motherboard connector J21.	<ul style="list-style-type: none"> • Check CPU fan cable connection. • If the problem persists, replace the CPU fan.
Fiery ZX hangs at the EFI logo when turned on.	Fiery ZX system software is corrupted or not installed on the hard disk drive.	<ul style="list-style-type: none"> • Install system software.
Startup diagnostics continue to run.	HDD is not installed properly.	<ul style="list-style-type: none"> • Check HDD installation. • If the problem persists you may need to replace the HDD.

5 Troubleshooting

TABLE 5-3 General Fiery ZX system error conditions (Continued)

Symptom	Probable cause	Suggested action
Check power & cable appears in the Fiery ZX Control Panel.	Problem with the connection between the Fiery ZX and the copier.	<ul style="list-style-type: none"> • Make sure the copier interface cable is connected to the Fiery ZX and the copier. • Make sure the copier is on and ready to print. • Print a Test Page. • If this does not correct the problem, you may need to replace the copier interface cable.
	Copier is not turned on when trying to print.	<ul style="list-style-type: none"> • Power on the copier and print a Test Page.
	Faulty video interface board.	<ul style="list-style-type: none"> • Run the video diagnostics from the Functions menu. • If the diagnostics indicate that the video interface board is bad, replace the board.
Boot file not found appears in the Fiery ZX Control Panel.	System software is corrupted on the HDD.	<ul style="list-style-type: none"> • Reinstall system software.

5

Checking the Fiery ZX as a stand-alone unit

Viewing the diagnostic Info screen

The Info screen displays device and version information for components installed on the Fiery ZX motherboard. The Info screen can be accessed during startup after the Fiery ZX completes its startup diagnostics.

TO DISPLAY THE DIAGNOSTIC INFO SCREEN

1. Restart the Fiery ZX using the power switch on the back panel.
2. While the Fiery ZX is running its startup diagnostics, hold down the fourth line selection button on the Control Panel to access the Installation & Info screen.

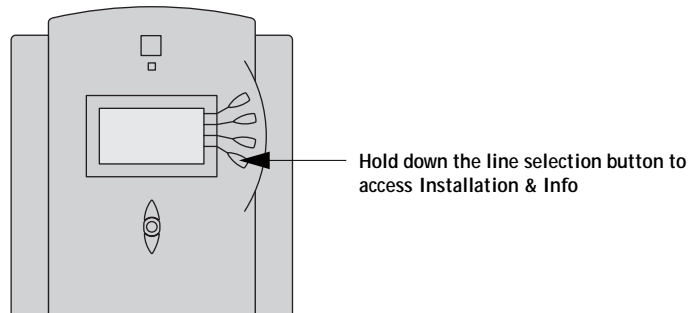

If you do not press the fourth line selection button before the end of the diagnostics, the Fiery ZX continues the startup process and you must restart the system and try again.

The following screen is then displayed.

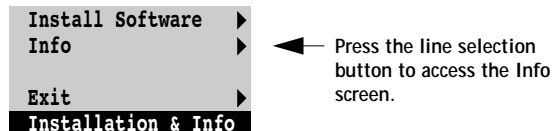

3. Press the line selection button next to Info to access configuration information.

5 Troubleshooting

Video interface board diagnostics

If you suspect there might be a problem with the video interface board (for example, the print quality of output is poor), you can run the Video Diagnostics to test components on the video interface board. The Video Diagnostics test loops data internally on the Fiery ZX video interface board. The Fiery ZX compares the data sent with the data received to make sure no errors have occurred. You can run Video Diagnostics once or you can select a time interval and run the video diagnostics repeatedly.

NOTE: Video interface board diagnostics do not test the STARR daughter card installed on the video interface board. If video interface problems occur, you should also check the STARR daughter card.

TO RUN VIDEO DIAGNOSTICS

1. Make sure the copier interface cable is removed from slot 5 on the back panel.
You will not get accurate results from this test if the copier interface cable is connected to the Fiery ZX.

2. Power on the Fiery ZX and at the Fiery ZX Idle screen, press the menu button once.

The Functions menu is shown below:

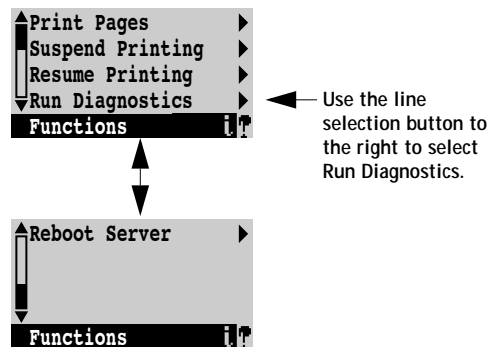

FIGURE 5-6 Run Diagnostics command on the Functions menu

3. Select Run Diagnostics from the Functions menu.

5

Checking the Fiery ZX as a stand-alone unit

- At the screen shown in Figure 5-7, select **Video Diagnostics**.

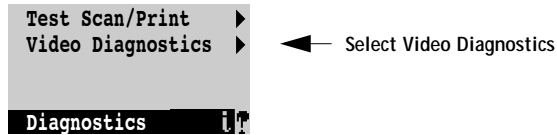

FIGURE 5-7 Video Diagnostics command

- Select **Single Pass** or **Multiple Pass** at the screen shown in Figure 5-8.

If you select **Single Pass**, the Video Diagnostics run through once. Selecting **Multiple Pass** runs the Video Diagnostics repeatedly.

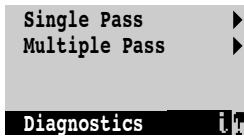

FIGURE 5-8 Video Diagnostics single pass or multiple pass

- If you selected **Multiple Pass**, enter how long you want to run the Video Diagnostics and then select **OK** to start the diagnostics.

Use the up and down buttons on the Control Panel to select the correct number and the line selection buttons to advance to the next space.

The time interval is set in minutes. This option should be set to a value between 1 minute and 8 hours.

- If the screen displays the message **Video diags failed**, then:
 - Power off the Fiery ZX and open the system (see “Accessing Fiery ZX internal components” on page 4-3).
 - Reseat the video interface board and the STARR daughter card.
 - Power on the Fiery ZX and run Video Diagnostics again. If the tests still fail you may need to replace the video interface board or the STARR daughter card.
- Once the Control Panel indicates that the video diagnostics passed, press the line selection button next to **OK** to return to the Functions menu.

5 Troubleshooting

Checking the entire Fiery ZX system

This phase of troubleshooting deals with problems with the entire system. These procedures should be run after verifying that the Fiery ZX functions properly as a stand-alone unit.

Checking the copier interface

After the Fiery ZX starts up successfully as a stand-alone unit, power off the Fiery ZX and connect the copier interface cable. Make sure the Fiery ZX is working properly with the copier before you connect it to the network. See “Connecting to the copier” on page 3-3.

Printing a Test Page

Once you have connected the Fiery ZX to the copier you should print the Test Page to verify that the interface between the copier and the Fiery ZX is working properly. The Test Page is a color PostScript file resident on the Fiery ZX HDD. The Test Page is printed to the copier using the settings configured in Setup.

TO PRINT A TEST PAGE

1. Make sure the copier is on.
2. Power on the Fiery ZX from the power switch on the back panel.
Messages appear on the Control Panel as the Fiery ZX runs through its startup diagnostics.
3. Before proceeding, make sure that the copier is not in use.
The Fiery ZX Info screen should read Idle.
4. Press the menu button once to display the Functions menu.

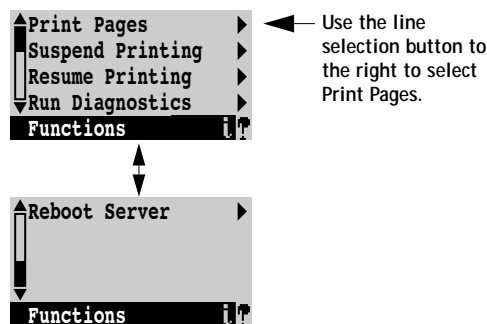

FIGURE 5-9 Functions menu commands

5

Checking the entire Fiery ZX system

5. Press the line selection button to the right of Print Pages and then select Test Page from the menu.

The Fiery ZX sends the Test Page to the copier and displays the RIP and Print status screens so you can monitor the job.

6. Examine the Test Page from the copier.

If the Test Page prints successfully, the Fiery ZX connection to the copier is working properly.

If the Test Page does not print at all or has a low-quality image, you may have a faulty video interface board or copier interface cable, or the copier may not be functioning properly. In these cases, check Fiery ZX connections and then run the Fiery ZX video interface board diagnostics (see “Video interface board diagnostics” on page 5-16) to locate the problem.

Checking scanning and printing

The Test Scan/Print diagnostic scans whatever is placed on the copier glass and prints it to the copier. This diagnostic test can be used to test the scanning capabilities on the Fiery ZX. You can compare the original with the output to make sure the connection between the Fiery ZX and the copier is working properly.

TO RUN TEST SCAN/PRINT

1. Place the document that you want to scan on the copier glass.
2. At the Idle screen, press the menu button once to display the Functions menu.

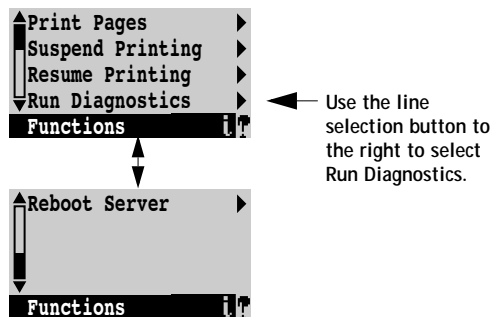

FIGURE 5-10 Run Diagnostics command on the Functions menu

3. Select Run Diagnostics from the Functions menu.

5 Troubleshooting

4. At the screen shown in Figure 5-11, select Test Scan/Print.
The message Scanning from copier and printing.... is displayed.

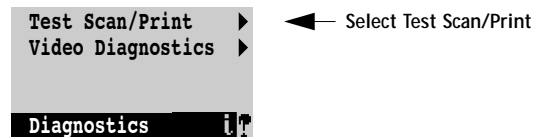

FIGURE 5-11 Test Scan/Print command

5. When the Fiery ZX is finished printing, compare the output from the copier to the original.

5

Checking network connections

Checking network connections

After the Fiery ZX is connected to networked computers, printing problems may arise if the network hardware or software is not set up properly or does not match network settings on the Fiery ZX. Problems may also arise when printing from a specific application or printing a particular file.

Most of these problems show up as printing problems, and do not necessarily indicate a Fiery ZX malfunction. The customer's network administrator can eliminate many printing problems without requiring you to make a service call. The network administrator deals with:

- Copier error conditions
- Network connection problems that result in the Fiery ZX not appearing in the printer list on the customer's workstation

NOTE: If the Fiery ZX does not appear in the list of printers on the network, there may be another device on the network with the same Ethernet hardware address.

- Conflicting network settings in Setup and on the customer's workstation
- Printing problems caused by the inappropriate Setup options
- Application-specific printing errors caused by missing or incorrectly placed printer description files

5 Troubleshooting

Printing to the Fiery ZX

If the user can print a Fiery ZX Test Page, but cannot print a job from a computer on the network, you may have to make a service call. However, first make sure the network administrator has:

- Checked all components of the network including cables, connectors, terminators, network adapter boards, and network drivers
- Activated the network and used it to communicate with other printers
- Checked the corrective actions listed in the *Printing Guide*
- Confirmed that the applicable network settings in Setup (such as AppleTalk zone, IP address, Subnet mask, and Gateway address) match the settings used in the network

When you make a service call, check the back panel of the Fiery ZX to make sure that the appropriate network connections are in place.

Intermittent print quality and color quality problems are difficult to trace. Before you try to troubleshoot print quality problems, copy a color Test Page to make sure that the copier itself does not need servicing or adjusting.

NOTE: EPS file generation is not completely standardized among applications. Some users may encounter problems while printing certain EPS files.

A

Hardware features

Appendix A: Specifications

This chapter provides an overview of Fiery ZX features.

Hardware features

- Alpha 21164 CPU—533MHz
- Memory—256MB for Fiery ZX3300; 160MB for Fiery ZX3200
- PostScript 3
- 4GB hard disk drive standard
- Built in CD-ROM drive

Networking and connectivity

- Supports AppleTalk, TCP/IP, and IPX protocols simultaneously
- AUI connector for thin or thick Ethernet
- Supports EtherTalk Phase 2
- RJ-45 connector that supports 10/100BaseT twisted pair network connectivity

User software

A complete description of Fiery ZX user software is provided in the *Printing Guide*. For optimal Fiery ZX performance, current versions of the user software should be maintained on every network computer that might print to the Fiery ZX.

Safety and emissions compliance

The Fiery ZX has been certified to meet or surpass the following government standards:

Safety approvals

- UL 1950
- CSA 22.2 #950
- EN 60950 (TUV/GS mark)
- CB scheme IEC 950

EMI approvals

- FCC Class A
- VCCI Class B
- EN55022 Class B

Index

Numerics

- 100BaseTX *xii*
- 10Base2 2-3, 3-9
- 10Base5 2-3, 3-9
- 10BaseT/100BaseT 2-3, 2-7, 3-8, 3-10

A

- activity light 2-7, 3-2, 3-13 to 3-14, 4-20, 5-9
- Adobe PS Printer Driver 1-4
- Alert screen 3-15 to 3-16
- AppleTalk 1-1
- AUI (attachment unit interface)
 - cable 3-9
 - connector 2-7, 3-8 to 3-9, 4-5, 4-25
 - slide latch 3-9, 4-25

B

- back panel
 - connectors 2-7, 4-5, 5-5
 - fan 4-36 to 4-37
 - screws 4-4
 - slot assignments 4-5
- banks, DIMM 4-29
- battery 4-31
 - motherboard location 4-23
 - troubleshooting 5-12
- beep codes 5-10
- BNC connector 3-9
- boards
 - HDD backplane 4-34, 4-40
 - motherboard 1-2, 4-23
 - MXV 4-8, 4-13 to 4-14
 - STARR daughter card 1-2, 4-17 to 4-19, 5-16
 - user interface 4-20
 - video interface 1-2, 4-8, 4-15
- boxes, unpacking 2-5
- bracket
 - CD-ROM drive 4-46
 - HDD 4-43 to 4-44
- buttons
 - accessing 4-6
 - down 2-7, 3-13 to 3-14, 4-20
 - line selection (move left/right) 2-7, 3-13 to 3-14, 4-20
 - menu 2-7, 3-13 to 3-14, 4-20
 - reset 2-7, 4-34
 - troubleshooting 5-13
 - up 2-7, 3-13 to 3-14, 4-20

C

- cables
 - AUI 3-9
 - category 5 3-10
 - checking 5-5
 - copier interface 2-5 to 2-6, 3-3 to 3-4
 - CPU fan 4-8, 4-37
 - Ethernet 3-7
 - fan, back panel 4-8, 4-36
 - parallel 2-5 to 2-6, 3-11
 - power 2-5 to 2-6, 3-1
 - power supply 4-8
 - reseating 4-8
 - SCSI 4-8
 - UIB 4-8, 4-20 to 4-21, 4-34, 4-43
 - UTP 3-10
- cancel
 - printing 3-16
 - processing 3-16
- category 5 cable 3-10
- CD
 - Command WorkStation 1-4, 2-5
 - system software 2-5, 4-49
 - user software 1-4, 2-5
- CD-ROM drive 2-7
 - bracket 4-46
 - door 2-7, 4-45
 - location 4-45
 - removal 4-45
 - replacement 4-46
- checking
 - cables 5-5
 - copier interface 3-5, 5-18
 - internal components 5-6
 - network connections 5-21
 - power & cable message 5-14
 - scanning and printing 3-6, 5-19
- checklist for service calls 2-3
- chips
 - CPU 1-2, 4-23
 - network 3-7
- Color Charts option 3-18
- Color Management files 1-5
- Color Reference files 1-5
- ColorWise 1-1
- COM1 2-7, 4-5
- COM2 2-7, 4-5
- Command WorkStation 1-4, 2-5, 3-7

Index

- components
 - checking 5-6
 - exploded view 4-2, 5-7
- Configuration page option 3-18
- connections
 - checking 3-5 to 3-6
 - copier interface 3-4
 - DIMM 4-10
 - Ethernet 3-8
 - network 3-7
 - power 3-1
 - reseating 4-8
 - thicknet (10Base5) 2-3, 3-9
 - thinnet (10Base2) 2-3, 3-9
 - twisted pair (10BaseT/100BaseT) 2-3, 3-8, 3-10
- connectors
 - 10BaseT/100BaseT 2-7
 - AUI 3-8 to 3-9, 4-5, 4-25
 - back panel 2-7, 4-5, 5-5
 - BNC 3-9
 - copier interface 2-7, 3-3, 4-5, 4-15
 - Ethernet 3-8
 - HDD 4-34
 - lpt1 3-12
 - motherboard 4-5, 4-23
 - network 3-8
 - parallel port 2-7, 3-8, 3-12, 4-5
 - power 2-7, 3-1, 4-5
 - replacing mounting hardware 4-27
 - RJ-45 2-7, 3-10
 - serial ports 2-7, 4-5
 - twisted pair (10BaseT/100BaseT) 3-8, 4-5
 - user interface 4-20
 - video interface 4-15
- Control Panel
 - activity light 2-7, 3-13
 - buttons 2-7, 3-13 to 3-14
 - definition *xii*
 - display window 3-13
 - jewels 2-7
 - Map 3-18
 - troubleshooting 5-13
 - using 3-13
- copier interface cable 2-5 to 2-6, 3-3 to 3-4
- copier interface connector 2-7, 3-3 to 3-4, 4-5, 4-15
- CPU 1-2, 4-23
 - fan 4-37
 - fan cable 4-8
 - jumper setting 4-32
 - troubleshooting 5-10
- customer site checklist 2-3
- D**
- damage, reporting *xiii*, 2-5
- diagnostics
 - beep codes 5-10
 - copier interface 5-18
 - Dsk test group 5-11
 - Ethernet address 5-21
 - Eth test group 5-11
 - Flh test group 5-12
 - Info screen 5-15
 - I/O test group 5-12
 - miscellaneous test group 5-11
 - RTC test group 5-12
 - Run Diagnostics option 3-19
 - startup 5-11
 - startup error numbers 5-11
 - startup errors 5-9
 - startup screen 5-9
 - Test Page 3-5, 5-18
 - Test Scan/Print 3-6, 3-19, 5-19
 - video 3-19, 5-16
- DIMMs
 - banks 4-29
 - configurations 1-2, 4-29
 - motherboard checking motherboard DIMMs 4-10
 - removal and replacement 4-30
 - sockets 4-29
 - troubleshooting 5-11
- display window
 - cleaning *xiii*
 - handling *xiii*
 - on user interface board 4-20
 - using 3-13
- documentation 2-5 to 2-6
- door 2-7
- down button 2-7, 3-13 to 3-14, 4-20
- Downloader 1-1, 1-3 to 1-4

Index

- drives
 - CD-ROM 4-45 to 4-46
 - hard disk 4-40
- E**
- EMI
 - approvals A-1
 - UIB enclosure 4-21 to 4-22
- EPS files, printing 1-3
- error numbers
 - 30 5-11
 - 80 5-12
 - 81 5-12
 - 90 5-11
 - 91 5-11
 - 92 5-11
 - 93 5-11
 - 94 5-11
 - E0-E1 5-12
 - E2 5-12
 - F1-F4 5-12
 - G0-G2 5-11
 - G3 5-11
 - H0-H2 5-11
 - I0-I4 5-11
 - I5 5-11
 - K0-K2 5-11
- errors
 - activity light 5-9
 - check power & cable 5-14
 - number 5-11
 - reporting with beep codes 5-10
 - startup 3-2, 5-9
 - system 5-13
- ESD (electrostatic discharge)
 - safety precautions *xiv*
- Ethernet
 - address 5-21
 - AUI 2-7
 - cabling 3-7
 - connectors 3-8
 - network adapter chip 3-7
 - networks 3-7
 - transceiver 2-5 to 2-6, 3-9
- Exit Setup screen 3-2
- exploded view 4-2, 5-7
- F**
- fan
 - back panel 4-36
 - cable, back panel 4-8, 4-36
 - CPU 4-37
 - CPU cable 4-8, 4-37
 - replacement on back panel 4-37
 - troubleshooting 5-13
- Fiery
 - Downloader 1-1, 1-3 to 1-4
 - Print Calibrator 1-4
 - Scan 1-1 to 1-2, 1-5
 - Spooler 1-5, 4-49
 - WebTools 1-4 to 1-5
- Fiery ZX3200
 - configuration *xii*
- Fiery ZX3300
 - configuration *xii*
- Flash ROM 5-10, 5-12
- Font List 3-18, 4-49
- fonts 1-1, 1-4, 4-49
- front cover
 - HDD bracket screws 4-43
- front panel 2-7, 3-13
 - components 4-6
 - removing 4-6 to 4-7
 - replacing 4-7
- Functions menu 3-5, 3-15, 3-18
 - Color Charts 3-18
 - Configuration page 3-18
 - Control Panel Map 3-18
 - Font List 3-18, 4-49
 - Job Log 3-18
 - Print Pages 3-18
 - Reboot Server 3-19
 - Resume Printing 3-19
 - Run Diagnostics 3-19
 - Suspend Printing 3-19
 - Test Page 3-18, 5-18
 - Test Scan/Print 3-19
 - Video Diagnostics 3-19
- Functions screen 3-17
- fuses 5-11
- G**
- guide pins 4-26 to 4-27, 4-34

Index

H

- hard disk drive
 - bracket 4-43 to 4-44
 - bracket screws 4-6, 4-43
 - description 4-40
 - removal 4-41
 - replacement 4-42
 - SCSI ID 4-40
- HDD 4-40 to 4-42
- HDD backplane board 4-34, 4-40
 - connectors 4-34
 - guide pins 4-34
 - removal 4-35
 - replacement 4-35
 - reset switch 4-34
 - speaker 4-34
- HDD bracket 4-43 to 4-44
- HDD bracket screws 4-43

I

- icons
 - Alert 3-16
 - Functions 3-17
 - Info 3-17
 - Network 3-17
 - Print 3-16
 - RIP 3-16
- Idle screen 3-2
- Info screen 3-15, 3-17
- Installation & Info screen 4-50, 5-15
- installation sequence 2-2
- initial startup 3-1
- IP address *xiii*

J

- J19 4-5, 4-8, 4-23
- J20 4-5, 4-8, 4-23
- J26 4-5, 4-8, 4-23
- J29 4-5, 4-8, 4-13
- J35 4-5, 4-8, 4-15 to 4-16, 4-23
- J36 4-5, 4-8, 4-23
- J6 4-7
- jewels 2-7, 4-6
- Job Log
 - option in Functions menu 3-18, 4-49
 - printing 3-18, 4-49
- jumpers, motherboard 4-32 to 4-33

L

- LAN (local area network) *xiii*
- language selection 3-2, 4-50
- latch 3-9, 4-25
- LED 2-7, 3-13 to 3-14, 4-20, 5-9
- line selection buttons 2-7, 3-13 to 3-14, 4-20
- lpt0 2-7
- lpt1 2-7, 3-12

M

- media package 2-5 to 2-6
- memory configurations 1-2, 4-29
- menu button 2-7, 3-13 to 3-14, 4-20
- menus
 - Functions 3-5, 3-15, 3-18
- models
 - Fiery ZX3200 *xii*
 - Fiery ZX3300 *xii*
- motherboard
 - battery 4-23, 4-31
 - completing and verifying installation 4-28
 - connectors 4-5, 4-8, 4-23
 - CPU 1-2, 4-23
 - CPU fan 4-37
 - description 1-2, 4-23
 - DIMMs 4-10, 4-29 to 4-30, 5-11
 - guide pin holes 4-26 to 4-27
 - illustrated 4-23
 - installation 4-27
 - jumpers 4-32 to 4-33
 - mounting screws 4-23
 - removal 4-24 to 4-26
 - removing connector mounting hardware 4-25
 - replacing connector mounting hardware 4-27
 - tray clips 4-26 to 4-27
 - troubleshooting 5-12
- move left/right buttons 2-7, 3-13 to 3-14, 4-20
- MXV board
 - description 4-13
 - motherboard connector 4-8
 - removal 4-14
 - replacement 4-14

Index

N

NetWise 1-1
network connections
 checking 5-21
 overview 3-8
 precautions *xiii*
 thicknet (10Base5) 2-3, 3-9
 thinnet (10Base2) 2-3, 3-9
 twisted pair (10BaseT/100BaseT) 2-3,
 3-8, 3-10
networks
 connecting the server to 3-7
 Ethernet 3-7
 icon 3-17
 Novell 1-1, 3-11
 supported 1-1 to 1-2, A-1
 Token Ring 3-7
Network screen 3-2
Novell networks 1-1, 3-11

O

On/Off switch 2-7
opening the system 4-3
options, installing 3-7

P

parallel cable 2-5 to 2-6
parallel port
 connection 1-2, 2-4, 3-11, 4-5
 connector 3-8, 3-12
 lpt0 2-7
 lpt1 2-7
 printing 1-3
PC-based servers, connecting 3-11
PDF 1-1, 1-3
Portable Document Format 1-1, 1-3
PostScript 3 1-1, 1-4
PostScript files, printing 1-3
PostScript Printer Description files 1-4
PostScript screen fonts 1-4

power

 cable 2-6, 3-1
 connector 2-7, 3-1, 4-5
 Off 3-20, 4-3
 precautions 2-3
 switch 2-7, 3-1
power cable 2-5
power supply
 cables 4-8
 description 4-37
 problems 5-13
 removal 4-39
 replacement 4-39
 voltages 3-2, 4-38
PPD files 1-4
precautions *xiii*
Print Calibrator 1-4
Printer screen 3-2
printing
 Color Charts 3-18
 Configuration page 3-18
 Control Panel Map 3-18
 copier test page 2-3
 Font List 3-18
 Job Log 3-18
 options 1-3
 pages 3-18
 problems 5-22
 server Test Page 3-5, 3-18, 5-18
Print Pages option 3-18
Print screen 3-15 to 3-16

R

reassembling the system 4-11 to 4-12
Reboot Server option 3-19
reseating connections 4-8
reset button 2-7, 4-34
restarting 3-20
Resume Printing option 3-19
RIP screen 3-15 to 3-16
RJ-45 connector 3-10
Run Diagnostics option 3-19

S

safety approvals A-1
scanning 1-1, 3-6, 5-19
screen fonts 1-4

Index

- screens
 - Alert 3-15 to 3-16
 - Exit Setup 3-2
 - Functions 3-5, 3-15, 3-17 to 3-18
 - Idle 3-2
 - Info 3-15, 3-17
 - Installation & Info 4-50, 5-15
 - language 3-2, 4-50
 - Network 3-2
 - Print 3-15 to 3-16
 - Printer 3-2
 - RIP 3-15 to 3-16
 - Server 3-2
 - Setup 3-2, 4-50
 - startup diagnostic 5-9
 - screw locations on back panel 4-4
 - SCSI cable 4-8
 - serial number 2-5
 - serial ports 2-7, 4-5
 - Server screen 3-2
 - service calls
 - checklist 2-3
 - tools required *xv*
 - service procedures, overview 4-1
 - Setup 3-9 to 3-10, 3-12, 4-50
 - Setup screens 3-2
 - shutting down 3-20, 4-3
 - side panel
 - reassembly 4-11
 - removing 4-3
 - screws 4-4, 4-11
 - slide latch 3-9, 4-25
 - slot assignments 3-4, 4-5, 4-23
 - slots
 - copier interface 3-3 to 3-4
 - MXV board 4-5
 - video interface board 4-5, 4-15
 - sockets, DIMMs 4-29
 - software
 - Command WorkStation 1-4, 2-5
 - media package 2-5 to 2-6
 - system 2-5, 4-1, 4-45, 4-49
 - user 1-4, 2-4 to 2-5, A-1
 - speaker 4-34
 - specifications A-1
 - Spooler 1-5, 4-49
 - SQE switch 3-9
 - STARR daughter card 1-2, 4-15, 4-17 to 4-19, 5-16
 - startup
 - diagnostic screen 5-9
 - errors 5-9
 - for installation 3-1
 - language selection 3-2
 - startup diagnostics
 - beep codes 5-10
 - Dsk test group 5-11
 - error numbers 5-11
 - Eth test group 5-11
 - Flh test group 5-12
 - I/O test group 5-12
 - miscellaneous test group 5-11
 - RTC test group 5-12
 - tests 5-11
 - Suspend Printing option 3-19
 - switch 2-7, 3-1
 - system errors 5-13
 - system software *xii*, 2-5, 4-1, 4-49
- ## T
- TCP/IP 1-1
 - terminology *xii*
 - test group
 - Dsk 5-11
 - Eth 5-11
 - Flh 5-12
 - I/O 5-12
 - miscellaneous 5-11
 - RTC 5-12
 - Test Page 5-18
 - copier 2-3
 - printing from the Function menu 3-5
 - server, description 3-18
 - Test Scan/Print 3-6, 3-19, 5-19
 - thicknet 2-3, 3-9
 - thinnet 2-3, 3-9
 - Token Ring 2-3, 3-7
 - tools required for service/installation *xv*
 - transceiver 2-5 to 2-6, 3-9
 - transceiver, SQE switch 3-9
 - tray clips 4-26 to 4-27

Index

troubleshooting
 battery 5-12
 beep codes 5-10
 buttons 5-13
 cache 5-10
 Control Panel 5-13
 CPU 5-10
 DIMMs 5-10 to 5-11
 fan 5-13
 Flash ROM 5-10, 5-12
 fuses 5-11
 motherboard 5-10, 5-12
 power supply 5-13
 printing problems 5-22
 process 5-1
 startup errors 5-9
 system error conditions 5-13
twisted pair (10BaseT/100BaseT) 2-3, 3-8, 3-10

U

UIB
 cable 4-8, 4-20 to 4-21, 4-34, 4-43
 enclosure 4-21 to 4-22
unpacking 2-5
up button 2-7, 3-13 to 3-14, 4-20
user interface board
 accessing 4-6
 activity light 4-20, 5-9
 connector 4-20
 description 4-20
 display window 4-20
 line selection buttons (move left/right buttons) 4-20
 menu button 4-20
 removal 4-21
 replacement 4-22
 UIB cable 4-21
 UIB enclosure 4-21 to 4-22
 up/down buttons 4-20
user software 2-4, A-1
User Software CD 1-4, 2-5
UTP (unshielded twisted pair) 3-10

V

Video Diagnostics option 3-19
video interface board
 copier interface connector 4-15
 description 1-2, 4-15
 diagnostics 5-16
 motherboard connector 4-8
 mounting bracket 4-15
 removal 4-16
 replacement 4-16
 STARR daughter card 4-15, 4-17 to 4-19, 5-16
voltage
 checking 3-2, 4-38

W

WebTools 1-4 to 1-5

